

CHLOE @ SKY68

Spider fitting frame-less glass Canopy

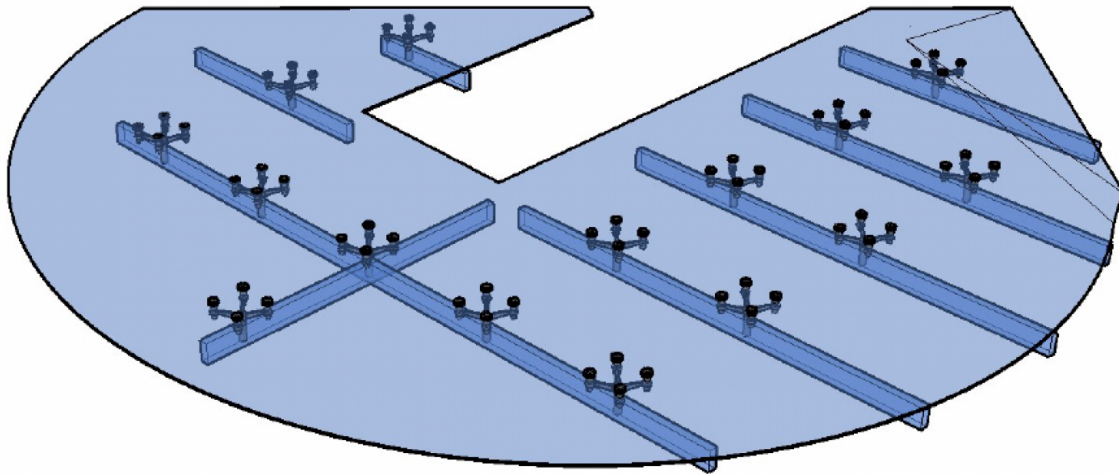

Spider system fitting frame-less glass Canopy Design to Comply below Specification

1. Building (Construction) Regulations Chapter 123-1990 ;
2. Code of Practice on Wind Effects Hong Kong -2004
3. Code of Practice for the structural use of Steel -2011
4. Code of Practice for the structural use of Concrete-2004 (2nd Edition)
5. Code of Practice for the structural use of Aluminium -BS8118: Part 1:1991
6. Practice Note for Authorized person, registered structural engineers and registered geotechnical engineers: BD APP-37 (PNAP 106)
7. Code of Practice for Dead and Imposed loads-2011

CHLOE @ SKY68

Spider fitting frame-less glass Canopy

Technical Data

Major Material:

- S.S 316 Spider System
- Stainless Steel Grade S316L with ASTM A511 and Plate with ASTM A240 Proof Stress = 220 MPa
- 8 mm THK Clear Laminated Tempered Glass comply BS 952 Part 1 and BS 6262 , Allowable Stress 50MPa
- Welding comply BS EN 1011-1; BS EN 1011-2; BS EN ISO 15614
- Stainless Steel Fasteners A4-70 comply wiht BS EN ISO 3506-1. Permanent Stain 450Mpa
- Sealants -Dow Corning 795/995/983 or Equivalent Material
- M16.S.S A4-70 Blot & Nut

Tempered Glass color

- Clear
- Dark Grey,
- Euro grey;
- Ocean blue,
- Ford blue,
- Dark blue

Tempered Glass Pattern

Custom-made

Design Basic Wing Pressure

2.04KPa

Color Finishes

- Hairline Finish

Certificate



Project	Fixture#	Date
		Firm



Ordering Information

Choose the option that suits your need and write its corresponding code on the appropriate line to form the product code.

Example product code:

CHLOE-AT-SKY68 -

CHLOE @ SKY68

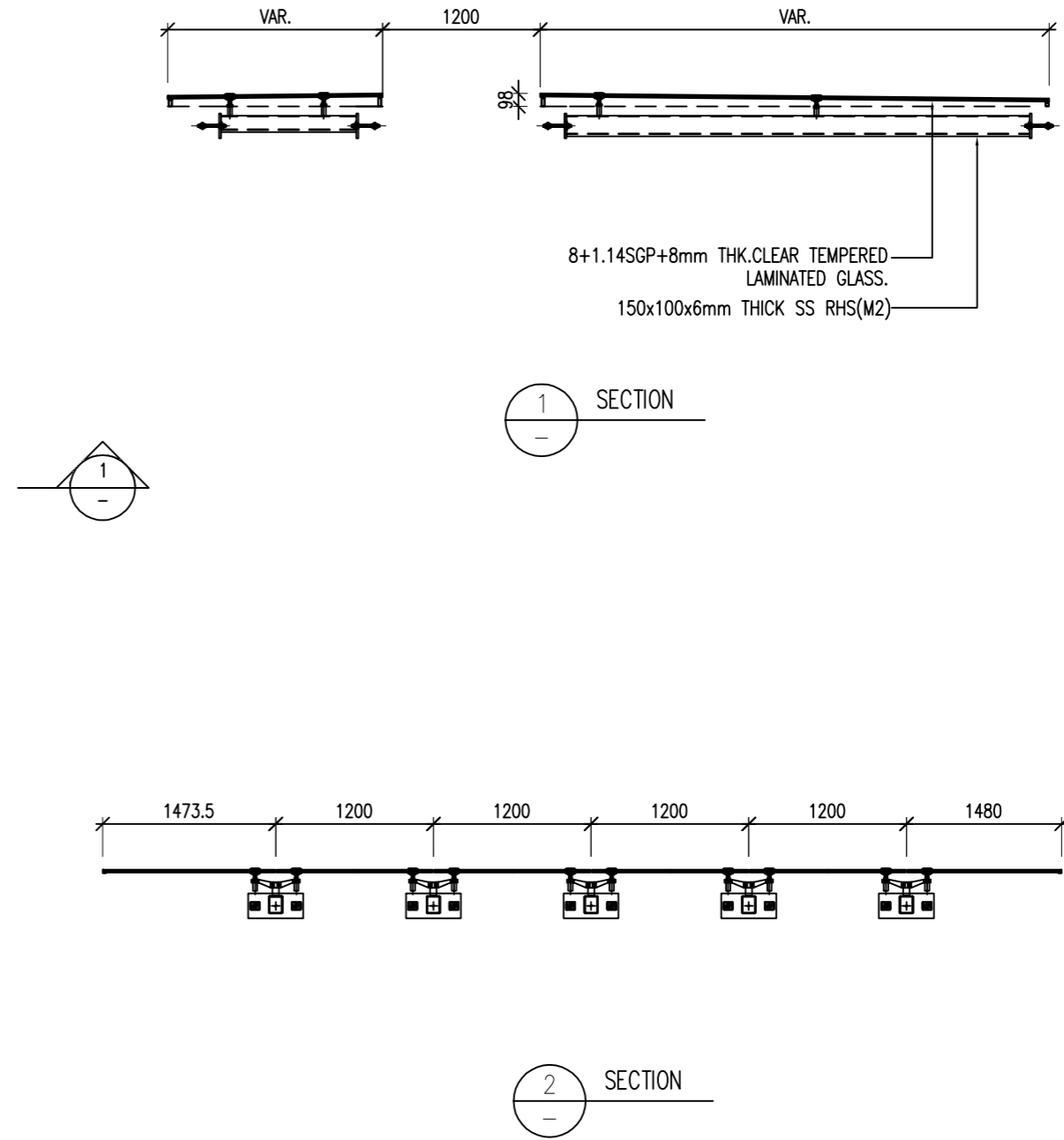
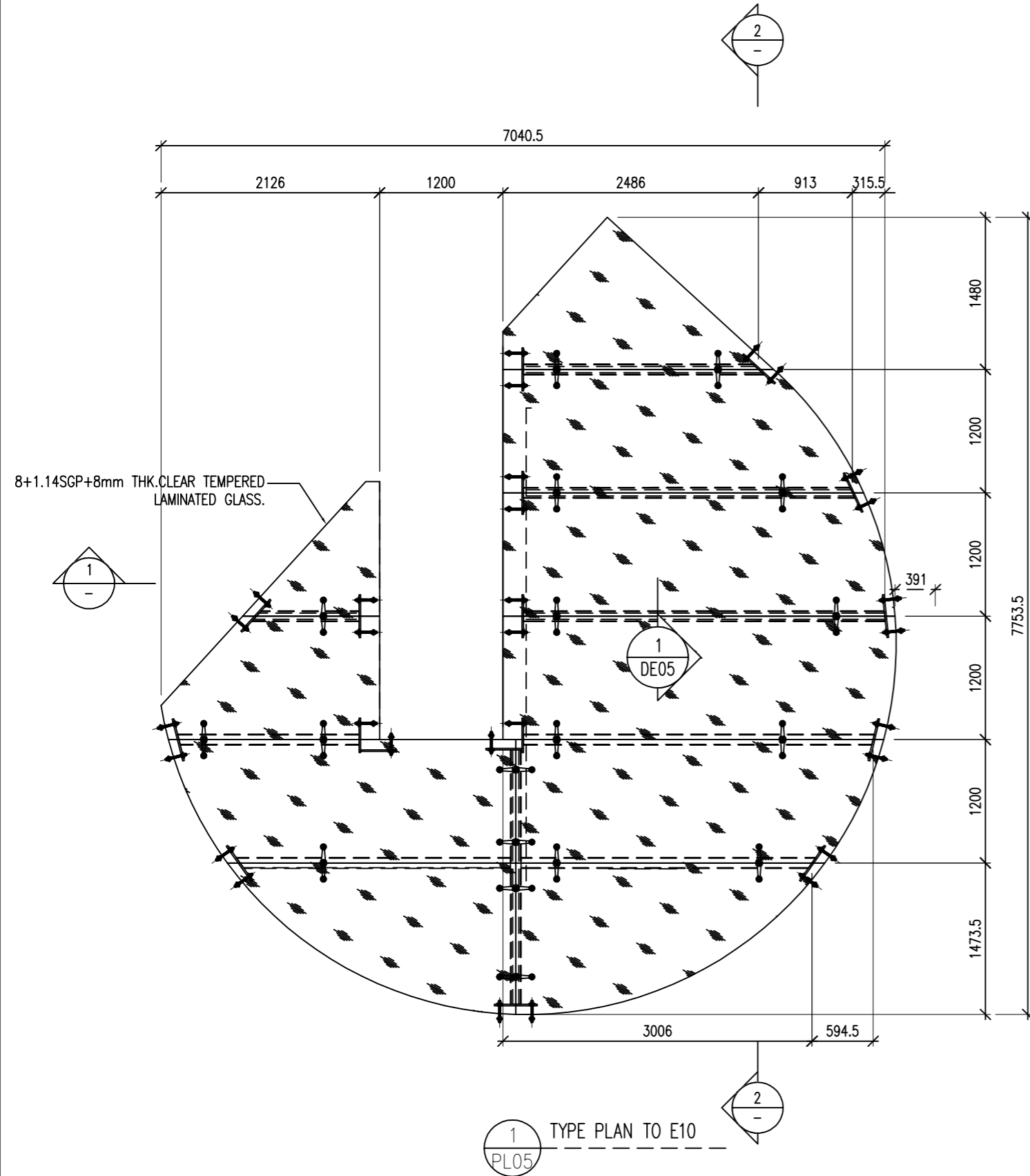

Drawing Status :

Ref NO.:

Client

Contractor:

Supplier:

DIMON
Technology

DIMON Technology Ltd.

Tel: 00852-3916 5876
Fax: 00852-21203398
Http://www.dimontechnology.com
E-mail:gary@dimontechnology.com

Project:

Job Title:

Drawing Name:

Drawing NO.:

Drawing Scale: AS SHOW

Drawing Date: 2020/06/30

Drawing: KP

Collate: Joyi

Auditing: Gray Hui

Drawing Version: 1

CHLOE @ SKY68

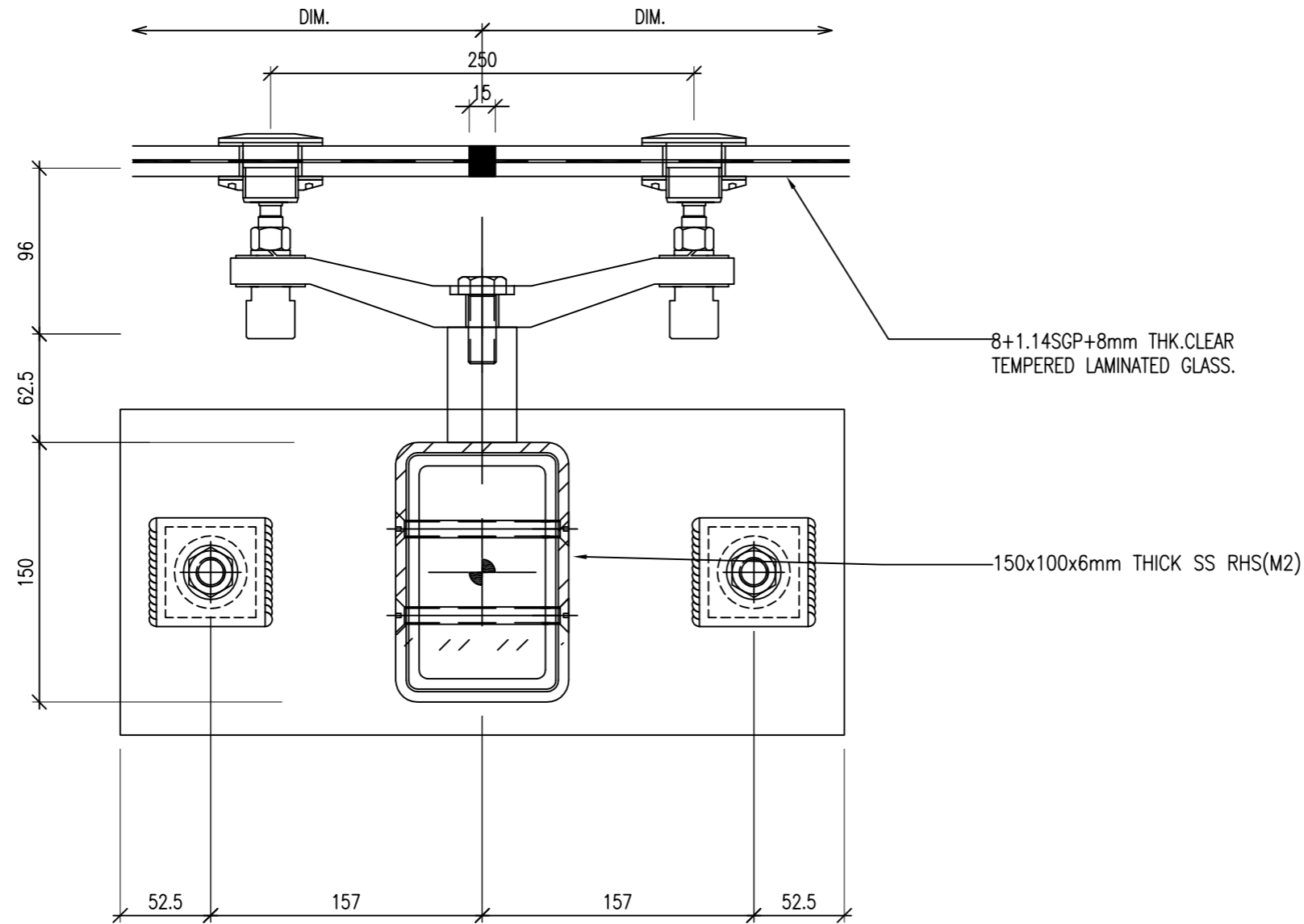

1
DE05

DETAIL

Drawing Status :

Ref NO.:

Contractor:

Supplier:

DIMON
Technology

DIMON Technology Ltd.

Tel: 00852-3916 5876

Fax: 00852-21203398

Http://www.dimontechnology.com

E-mail:gary@dimontechnology.com

Project:

Job Title:

Drawing Name:

Drawing NO.:

Drawing Scale: AS SHOW

Drawing Date: 2020/06/30

Drawing: KP

Collate: Joyi

Auditing: Gray Hui

Drawing Version: 1

Table of content

Page

1.	Introduction	1
2.	Design Code, Design Data	2 - 3
3.	Design loads	3
4.	Check for laminated tempered glass	4 - 10
5.	Check for steel frame	11 - 14

Appendix

Sheet No.	1
Prepared by	Y.S.Zhang
Date	16.07.2020
Revision	-

Project

Title

CHLOE @ SKY68

1. Introduction

The skylights are made of 12+12mm thick laminated tempered glass fixed to s.s. RHS by means of stainless steel spider system. The objective of this calculation is to check the design of skylight to be safe against the dead load, live load and wind load.

Load path

Wind load to skylight → glass panels → s.s. spiders → steel RHS frame → gms embeds → r.c. structures

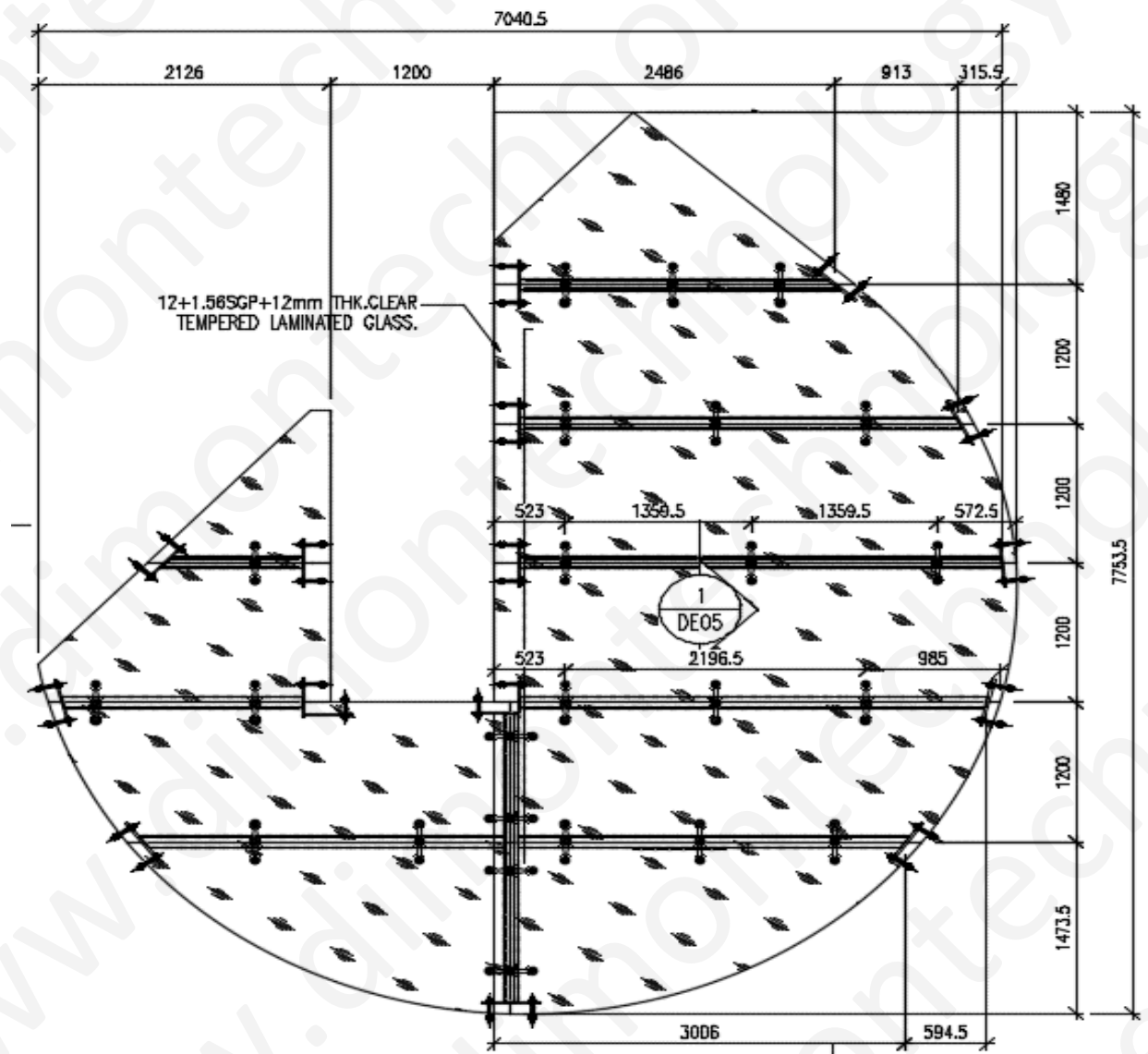

Sheet No.	2
Prepared by	Y.S.Zhang
Date	16.07.2020
Revision	-

Project	
Title	CHLOE @ SKY68

2. Design Code, Design Data

2.1 Design Code

- a) Hong Kong Building (Construction) Regulation 1990 (Amendment 2011).
- b) Code of Practice on Wind Effect 2008, Macau.
- c) Code of Practice for the Structural Use of Steel 2011, Hong Kong
- d) Code of Practice for the Structural Use of Concrete 2004, Hong Kong
- e) Code of Practice for Dead and imposed Loads 2011, Hong Kong
- f) Code of Practice for the Structural Use of Steel GB 50017-2003
- g) Load Code of the design of buliding structure GB 50009-2012

2.2 Design Data

2.2.1 Stainless steel to be grade X5CrNiMo17-12-2 complied with BS EN 10088

		1.4401 (316 S31)
stainless steel grade		X5CrNiMo17-12-2
0.2% proof stress	(N/mm ²)	220
ultimate tensile strength, min.	(N/mm ²)	510
Modulus of elasticity	(N/mm ²)	200000
Design strength	(N/mm ²)	220
Design stress of fillet weld	(N/mm ²)	220

2.2.2 All welding to be complied with complied to GB50661-2011

steel grade		E50xx
design strength of filled weld	(N/mm ²)	200

2.2.3 All stainless steel bolts or screws to be grade A4 complied to BS EN ISO 3506

class		70
0.2% proof stress	(N/mm ²)	450
ultimate tensile strength	(N/mm ²)	700
design tensile strength	(N/mm ²)	373
design shear strength	(N/mm ²)	280
design bearing strength	(N/mm ²)	805
stainless steel grade		A4 / 316
design bearing strength on connected part	(N/mm ²)	479

Sheet No.	3
Prepared by	Y.S.Zhang
Date	16.07.2020
Revision	-

Project		Date	16.07.2020
Title	CHLOE @ SKY68	Revision	-

2.2.4 Concrete

concrete strength,	f_{cu} (N/mm ²)	45	
anchorage bond strength, (= $\beta f_{cu}^{0.5}$)	f_{bu} (N/mm ²)	1.878	$\beta = 0.28$ for cast-in threaded rod
design concrete shear stress,	v_c (N/mm ²)	0.4	
compressive strength, (= $0.6 f_{cu}$)	(N/mm ²)	27	

2.2.5 The date refer to SAP2000 program.

3. Design Load

3.1 Wind load

Wind pressure,	$q_z = 1.84$	kPa	(height above ground level $\leq 10m$)
Pressure coefficient,	$= 2$		(open frame)
Design wind load	$= 2.12 \times 2.0$		
	$= 3.68$	kPa	

3.2 Live load

Live load	$= 0.75$	kN/m ²	
-----------	----------	-------------------	--

3.3 Dead Load

Weight of glass	$= (12 + 12) \times 26.5 / 1000$		$= 0.636$ kPa
Others,	$=$		$= 0.064$ kPa
		Total	$= 0.7$ kPa

Sheet No.	4
Prepared by	Y.S.Zhang
Date	16.07.2020
Revision	-

Project

Title

CHLOE @ SKY68

4. Check for laminated tempered glass

4.1 Check for 12mm+1.56PVB+12mm clear laminated tempered glass (6 point + 2 side supports)

Glass density, $\rho = 2650 \text{ kg/m}^3$
 Nominal thickness of glass pane 1 = 12 mm Min. thickness of glass pane 1, $t_1 = 11.91 \text{ mm}$
 Nominal thickness of glass pane 2 = 12 mm Min. thickness of glass pane 2, $t_2 = 11.91 \text{ mm}$

Glass type for pane 1 & 2	: tempered	Ultimate design strength,	$p_y = 80$	N/mm ²
Load duration	: short term	Reduction factor,	$\gamma_d = 1$	
Surface treatment	: clear	Reduction factor,	$\gamma_s = 1$	
		Material factor,	$\gamma_m = 1$	
Ultimate resistance strength,	$R_{ult} = p_y \gamma_d \gamma_s / \gamma_m$		$= 80$	N/mm ²

Comb 1: 1.3DL + 1.05LL + 0.9WL;

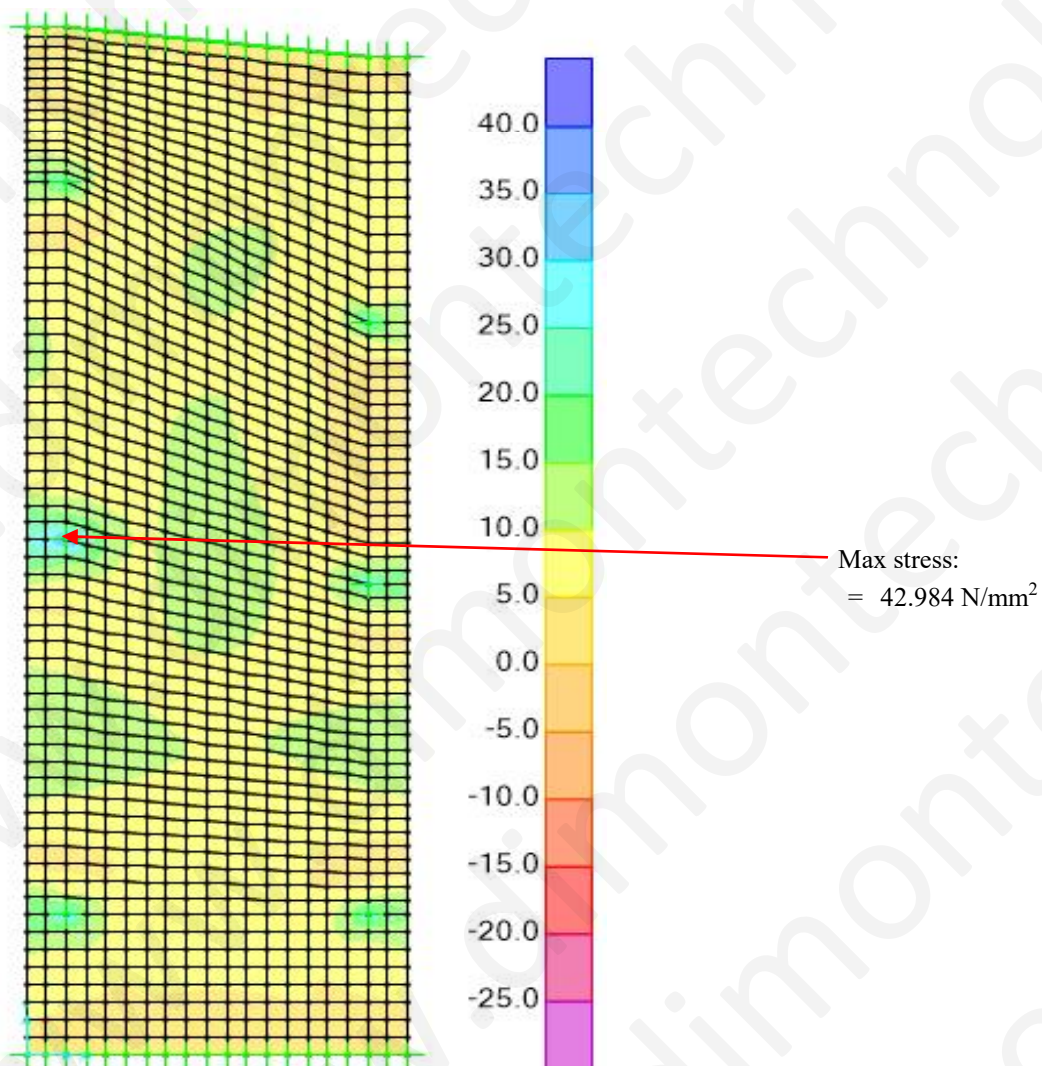

Sheet No.	5
Prepared by	Y.S.Zhang
Date	16.07.2020
Revision	-

Project	
Title	CHLOE @ SKY68

Comb 2: 1.2DL + 1.5LL + 0.9WL;

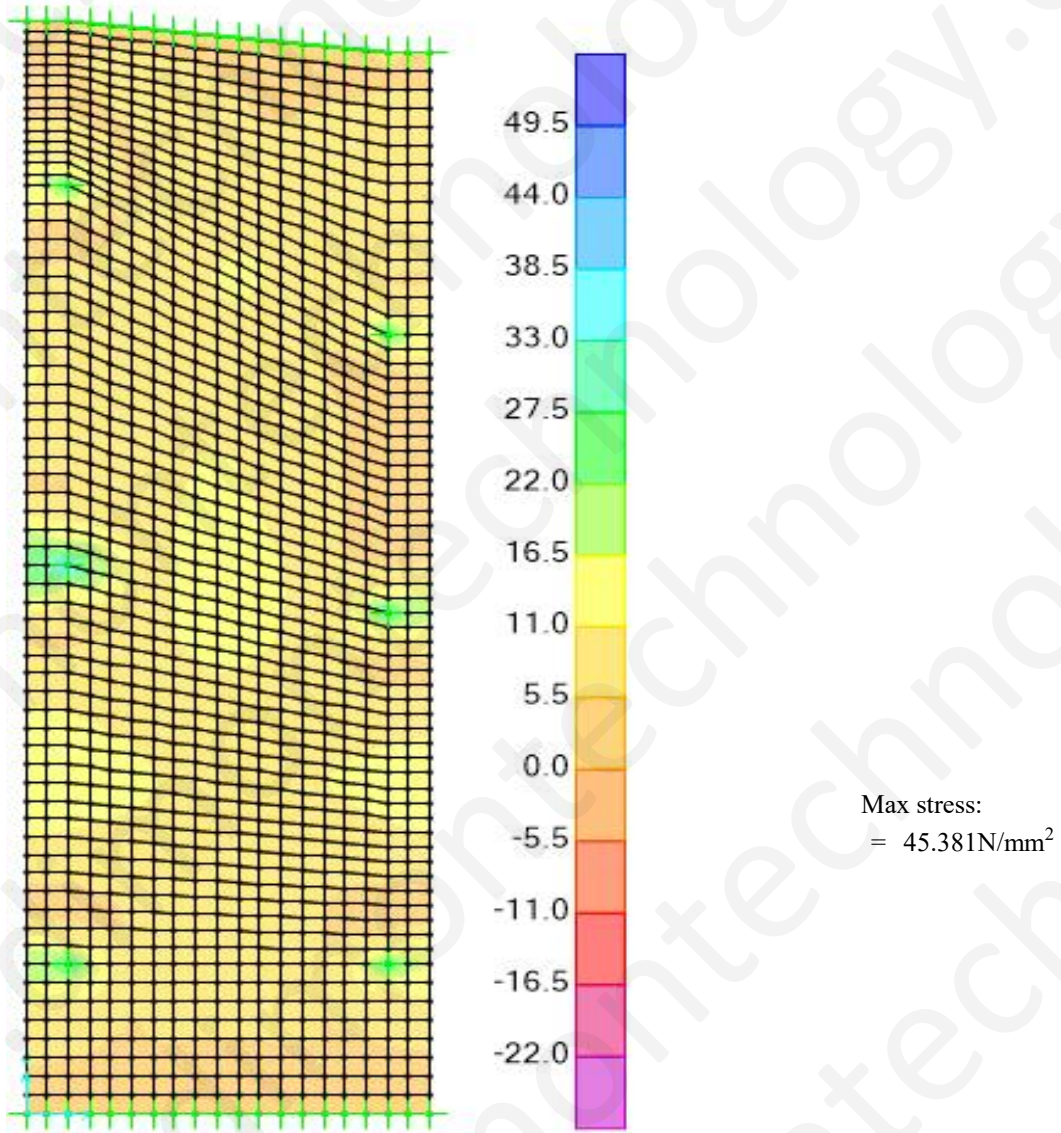

Comb 3: 1.2DL + 1.05LL + 1.5WL;

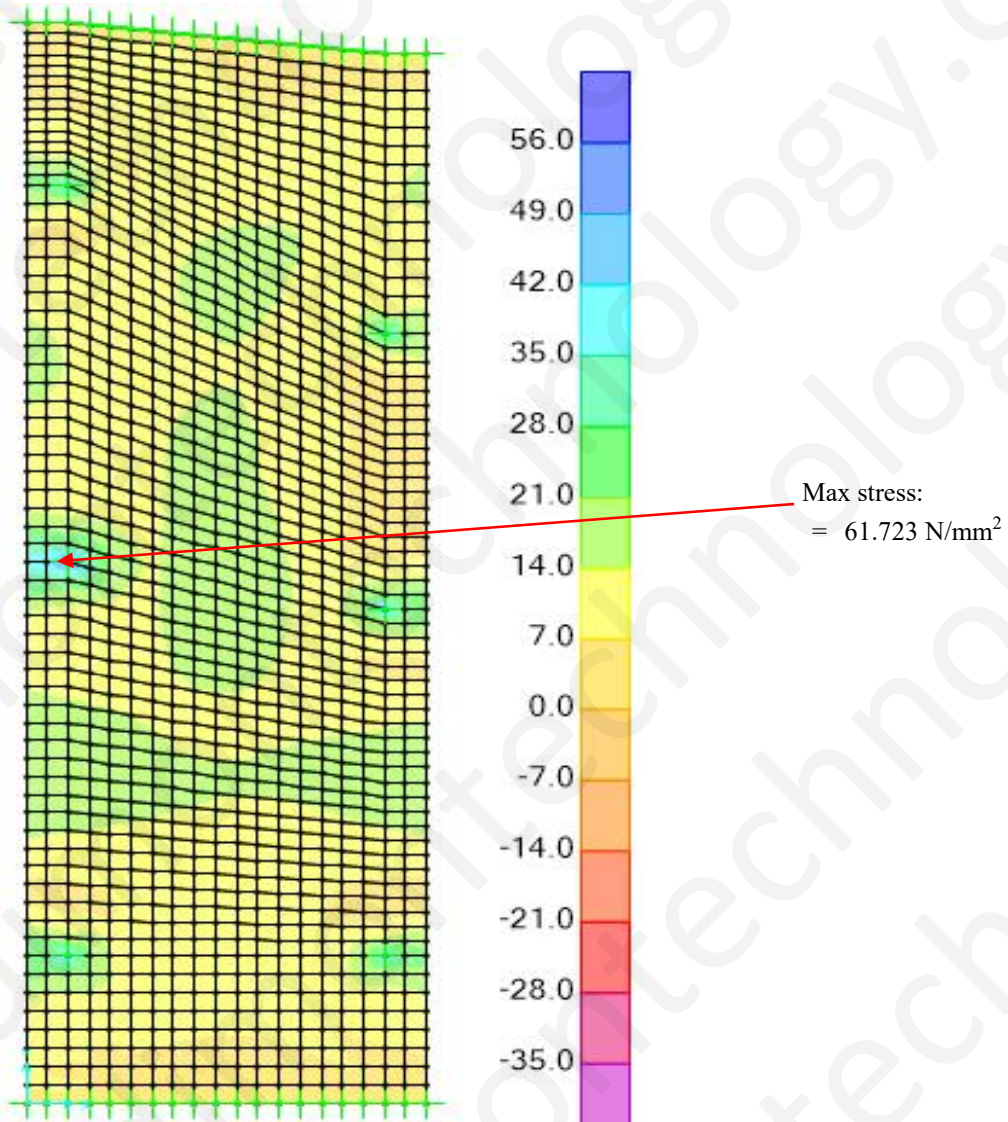

Sheet No.	7
Prepared by	Y.S.Zhang
Date	16.07.2020
Revision	-

Project		Date	16.07.2020
Title	CHLOE @ SKY68	Revision	-

Comb 4: 1.0DL + 1.0WL; (for deflection checking)

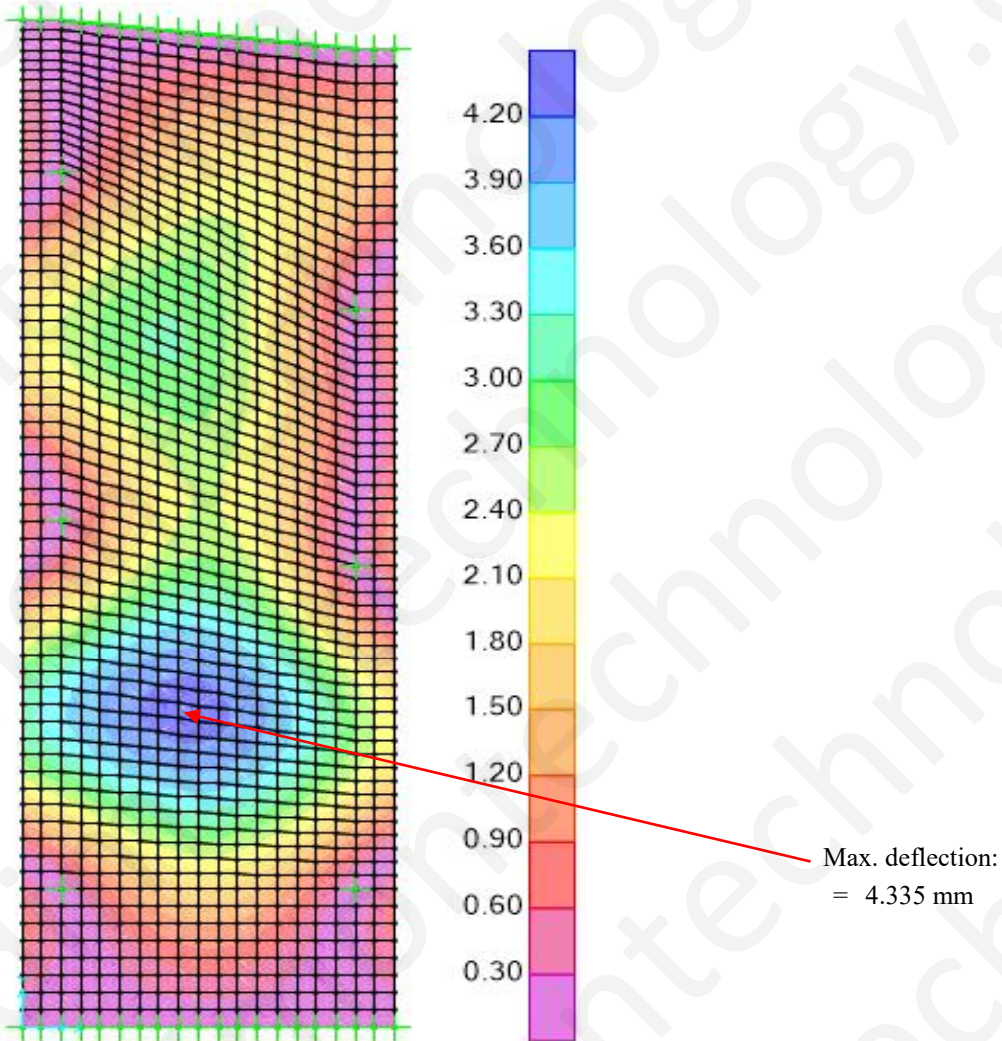

Max. bending stress of glass pane,

$$\sigma_{c1} = 61.723 \text{ N/mm}^2 \leq 80 \text{ N/mm}^2 \quad \text{O.K.}$$

Max. deflection,

$$\delta_c = 4.335 \text{ mm} \leq 950 / 60 = 15.83 \text{ mm} \quad \text{O.K.}$$

Check for structural sealant

$$\begin{aligned} \text{Structural sealant bite required} &= 3.68 \times 0.985 / 2 / 0.138 \\ &= 15.13 \text{ mm} \\ &\leq 26 \text{ mm} \quad \text{O.K.} \end{aligned}$$

		Sheet No.	8
		Prepared by	Y.S.Zhang
Project		Date	16.07.2020
Title	CHLOE @ SKY68	Revision	-

4.2 Check for flat cap routel (Kin Long TF12)

Table: Joint Reactions

Joint	Output Case	CaseType	F1	F2	F3	M1	M2	M3
			KN	KN	KN	KN-m	KN-m	KN-m
9	COMB1	Combination	0	0	1.652	0	0	0
9	COMB2	Combination	0	0	1.745	0	0	0
9	COMB3	Combination	0	0	2.373	0	0	0
9	COMB4	Combination	0	0	1.448	0	0	0
10	COMB1	Combination	0	0	1.542	0	0	0
10	COMB2	Combination	0	0	1.628	0	0	0
10	COMB3	Combination	0	0	2.215	0	0	0
10	COMB4	Combination	0	0	1.351	0	0	0
11	COMB1	Combination	0	0	1.514	0	0	0
11	COMB2	Combination	0	0	1.598	0	0	0
11	COMB3	Combination	0	0	2.174	0	0	0
11	COMB4	Combination	0	0	1.326	0	0	0
12	COMB1	Combination	0	0	1.559	0	0	0
12	COMB2	Combination	0	0	1.646	0	0	0
12	COMB3	Combination	0	0	2.238	0	0	0
12	COMB4	Combination	0	0	1.366	0	0	0
232	COMB1	Combination	0	0	2.115	0	0	0
232	COMB2	Combination	0	0	2.233	0	0	0
232	COMB3	Combination	0	0	3.037	0	0	0
232	COMB4	Combination	0	0	1.853	0	0	0
856	COMB1	Combination	0	0	1.681	0	0	0
856	COMB2	Combination	0	0	1.775	0	0	0
856	COMB3	Combination	0	0	2.414	0	0	0
856	COMB4	Combination	0	0	1.473	0	0	0

$$\begin{aligned}
 \text{Vertical load} &= 0.7 + 0.75 + 4.24 && \text{(DL+LL + WL)} \\
 &= 5.69 \quad \text{kN/m}^2 && \text{(unfactored)} \\
 &= 1.2 \times 0.7 + 1.05 \times 0.75 + 1.5 \times 4.24 && \text{(1.2DL+1.05LL +1.5 WL)} \\
 &= 7.99 \quad \text{kN/m}^2 && \text{(factored)} \\
 \text{Vertical load on routel at centre} &= 3.037 \times 5.69 / 7.99 \\
 &= 2.16 \quad \text{kN}
 \end{aligned}$$

Sheet No.	9
Prepared by	Y.S.Zhang
Date	16.07.2020
Revision	-

Project	
Title	CHLOE @ SKY68

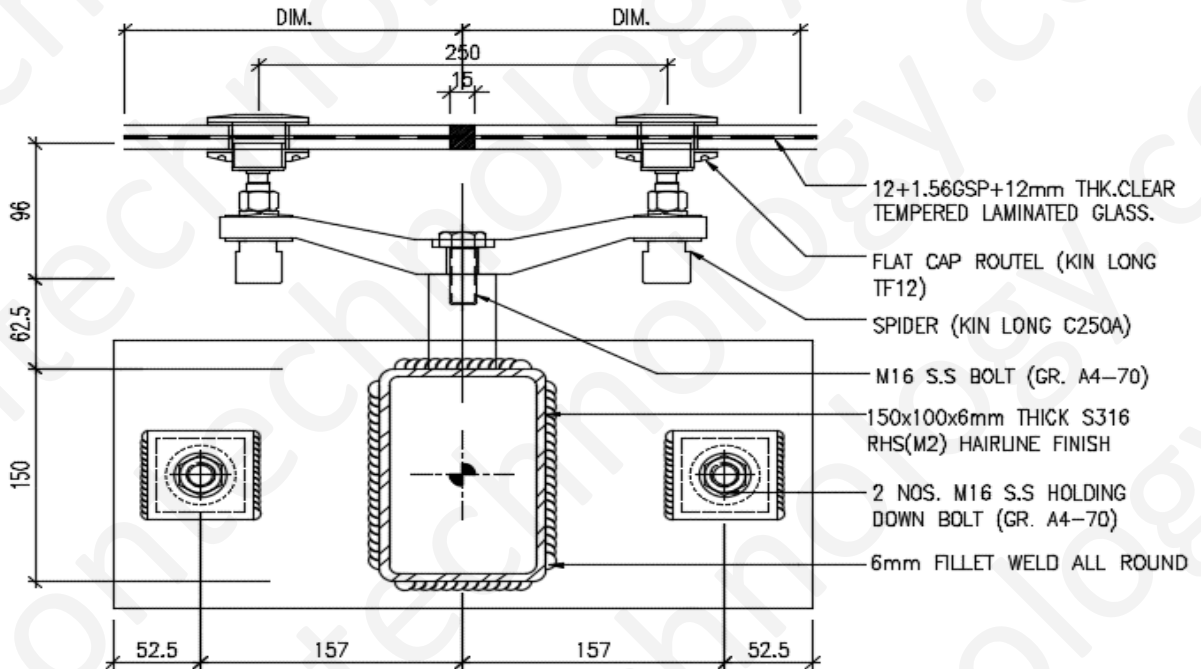

Reaction on each routel point
tension/compression = 2.16 kN (refer to Appendix)
< 4.5 kN O.K.

4.3 Check for spider (Kin Long C250A)

Vertical load on spider = 2.16 kN (refer to item 4.2)

Reaction on each spider
tension/compression = 2.16 kN (refer to Appendix)
< 4 kN O.K.

4.4 Check for M16 s.s. bolt, A4-70

Vertical load = 2 x 3.037
= 6.074 kN (refer to item 4.2)

Tensile area of M16 bolt = 156 mm²
Tensile strength of M16 bolt = 373 N/mm²
Shear strength of M16 bolt = 280 N/mm²

Sheet No.	10
Prepared by	Y.S.Zhang
Date	16.07.2020
Revision	-

Project	
Title	CHLOE @ SKY68

Tensile capacity of bolt

$$\begin{aligned} &= 156 \times 373 / 1000 \\ &= 58.19 \quad \text{kN} \\ &> 6.074 \quad \text{kN} \end{aligned} \quad \text{O.K.}$$

Pull out capacity on connected part,

$$\begin{aligned} &= 16 \times 3.1416 \times 10 / 2 \times 127 / 1000 \\ &= 31.919 \quad \text{kN} \\ &> 6.074 \quad \text{kN} \end{aligned} \quad \text{O.K.}$$

Check for 5mm fillet weld connector channel to steel frame

Horizontal load,

$$= 6.074 \quad \text{kN}$$

Effective length of fillet weld,

$$\begin{aligned} &= 2 \times 3.14 \times 23 \\ &= 144.44 \quad \text{mm} \end{aligned}$$

Capacity of fillet weld

$$\begin{aligned} &= 160 \times 144.44 \times 5 \times 0.7 / 1000 \\ &= 80.886 \quad \text{kN} \\ &> 6.074 \quad \text{kN} \end{aligned} \quad \text{O.K.}$$

Sheet No.	11
Prepared by	Y.S.Zhang
Date	16.07.2020
Revision	-

Project
Title

CHLOE @ SKY68

5. Check for steel frame

5.1 Check for 150x100x6mm s.s. RHS

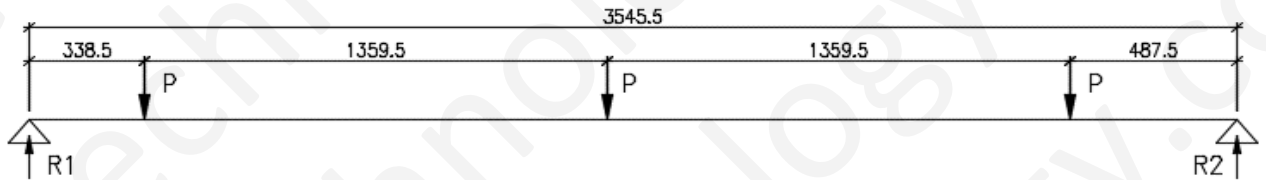

Vertical load, $P = 2 \times 3.037$ (refer to item 4.2)
 $= 6.074 \text{ kN}$ (factored)

Reaction at support $R1 = (3207 / 3545.5 + 1847 / 3545.5 + 487.5 / 3545.5) \times 6.074$
 $= 9.493 \text{ kN}$

$R2 = 3 \times 6.074 - 9.493$
 $= 8.729 \text{ kN}$

Max bending moment $= 9.493 \times 1.698 - 6.074 \times 1.3595$
 $= 7.86 \text{ kNm}$

Shear stress $= 9.493 \times 1000 / (2 \times 6 \times 150)$
 $= 5.27 \text{ N/mm}^2$
 $< 0.6 \times 127 = 76.2 \text{ N/mm}^2$ (low shear)

Moment capacity $= \min(1.2 p_y Z_y, p_y S_y)$
 $= (1.2 \times 220 \times 115/1000, 220 \times 141 / 1000)$
 $= 30.36 \text{ kNm}$ (factored)
 $> 7.86 \text{ kNm}$ O.K.

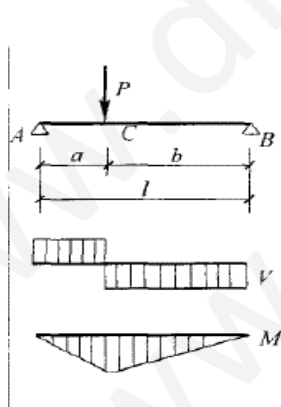

$R_A = \frac{Pb}{l}$
 $R_B = \frac{Pa}{l}$

A - C 段: $M_x = \frac{Pbx}{l}$
 C - B 段: $M_x = Pa \left(1 - \frac{x}{l} \right)$
 $M_{\max} = M_C = \frac{Pab}{l}$

A - C 段:

$w_x = \frac{Pbx}{6EI} (l^2 - b^2 - x^2)$

C - B 段:

$w_x = \frac{Pa(l-x)}{6EI} (2lx - a^2 - x^2)$

$w_C = \frac{Pa^2 b^2}{3EI}$

若 $a > b$, 当 $x = \sqrt{\frac{a}{3}(a+2b)}$:

$w_{\max} = \frac{Pb}{9EI} \sqrt{\left(\frac{a^2 + 2ab}{3} \right)^3}$

Sheet No.	12
Prepared by	Y.S.Zhang
Date	16.07.2020
Revision	-

Project	
Title	CHLOE @ SKY68

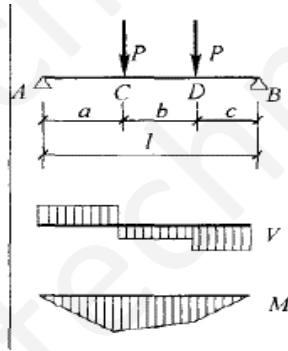

$$R_A = \frac{P}{l}(2c+b)$$

$$R_B = \frac{P}{l}(2a+b)$$

$$M_C = M_{\max} = \frac{Pa}{l}(2c+b)$$

若 $a > c$

$$w_C = \frac{Pa}{6EI}[(2a+c)l^2 - 4a^2l + 2a^3 - a^2c - c^3]$$

$$w_D = \frac{Pc}{6EI}[(2c+a)l^2 - 4c^2l + 2c^3 - ac^2 - a^3]$$

Max deflection = $1/48 P_k L^3 (3\alpha - 4\alpha^3) / (EI) + P_k a [(2c+a)L^2 - 4c^2L + 2c^3 - ac^2 - a^3] / (6EI)$
 = 8.38 mm (unfactored)
 < 3545.5 / 250 = 14.18 mm O.K.

Check for lateral torsional buckling

Design strength,	p _y = 220	N/mm ²	Parameter,	ε = (275 / p _y) ^{0.5} = 1.118
Modulus of Elasticity,	E = 200000	N/mm ²		
Overall width,	B = 100	mm	Overall depth,	D = 150 mm
Wall thickness,	t = 6	mm	Area,	A = 28.2 cm ²
Moment of inertia,	I _x = 862	cm ⁴	Moment of inertia,	I _y = 456 cm ⁴
Section modulus,	Z _x = 115	cm ³	Section modulus,	Z _y = 91.2 cm ³
Plastic modulus,	S _x = 141	cm ³	Plastic modulus,	S _y = 106 cm ³
Torsional constant,	J = 946	cm ⁴	Radius of gyration,	r _y = 4.02 cm
Effective length,	L _E = 3545.5	mm		
Slenderness ratio,	λ = L _E / r _y			= 88.2
	γ _b = (1 - I _y / I _x) [1 - J / (2.6 I _x)]			= 0.2722
Buckling index,	σ _b = [S _x ² γ _b / (A J)] ^{0.5}			= 0.4504
Ratio,	β _w = 1			for plastic section
Equivalent slenderness,	λ _{LT} = 2.25 (σ _b λ β _w) ^{0.5}			= 14.18
	P _E = π ² E / λ _{LT} ²			= 9816.97
	α _{LT} = 7			
	λ _{L0} = 0.4 (π ² E / p _y) ^{0.5}			= 37.89
Perry factor,	η _{LT} = α _{LT} (λ _{LT} - λ _{L0}) / 1000			= -0.166 < 0
	σ _{LT} = [p _y + (η _{LT} + 1) P _E] / 2			= 4203.68
Bending buckling strength,	p _b = P _E p _y / (σ _{LT} ² + (σ _{LT} ² - P _E p _y) ^{0.5})			
	= 265.25	N/mm ²		
	> 220	N/mm ²		

<h1 style="text-align: center;">DIMON</h1> <p style="text-align: center;">TECHNOLOGY</p>		Sheet No.	13
		Prepared by	Y.S.Zhang
Project		Date	16.07.2020
Title	CHLOE @ SKY68	Revision	-

5.2 Check for 6mm fillet weld all round connection to base plate

Vertical load = 9.493 kN (refer to item 5.1)

Properties for unit throat thickness of fillet weld (effective length)

Breadth, $B = 100$ mm
 Height, $D = 150$ mm
 Area, $A = 2(B + D) = 500$ mm²
 Moment of inertia, $I_x = B D^2 / 2 + D^3 / 6 = 1687500$ mm⁴
 Moment of inertia, $I_y = B^2 D / 2 + B^3 / 6 = 916667$ mm⁴
 Polar moment of inertia, $J = I_x + I_y = 2604167$ mm⁴

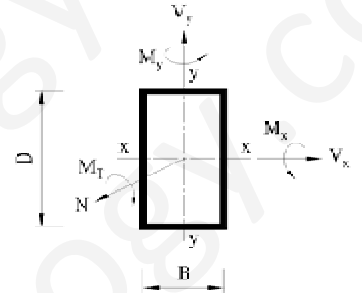

Shear load, $V_x = 0$ kN Moment, $M_x = 0$ kNm
 Shear load, $V_y = 9.493$ kN Moment, $M_y = 0$ kNm
 Tensile load, $N = 0$ kN Torsional moment, $M_T = 0$ kNm

Leg length of fillet weld, $t = 6$ mm

Shear stress, $\tau_x = V_x / (0.7 t A) + M_T (D / 2) / (0.7 t J) = 0$ N/mm²
 Shear stress, $\tau_y = V_y / (0.7 t A) + M_T (B / 2) / (0.7 t J) = 4.52$ N/mm²
 Tensile stress, $\sigma = N / (0.7 t A) = 0$ N/mm²
 Tensile stress, $\sigma_x = M_x D / (2 I_x) / (0.7 t) = 0$ N/mm²
 Tensile stress, $\sigma_y = M_y B / (2 I_y) / (0.7 t) = 0$ N/mm²

Resultant , $f_w = [\tau_x^2 + \tau_y^2 + (\sigma + \sigma_x + \sigma_y)^2]^{0.5}$
 $= 4.52$ N/mm²
 ≤ 200 N/mm²

O.K.

Sheet No.	14
Prepared by	Y.S.Zhang
Date	16.07.2020
Revision	-

Project

Title

CHLOE @ SKY68

5.3 Check for M16 holding down bolt, A4-70

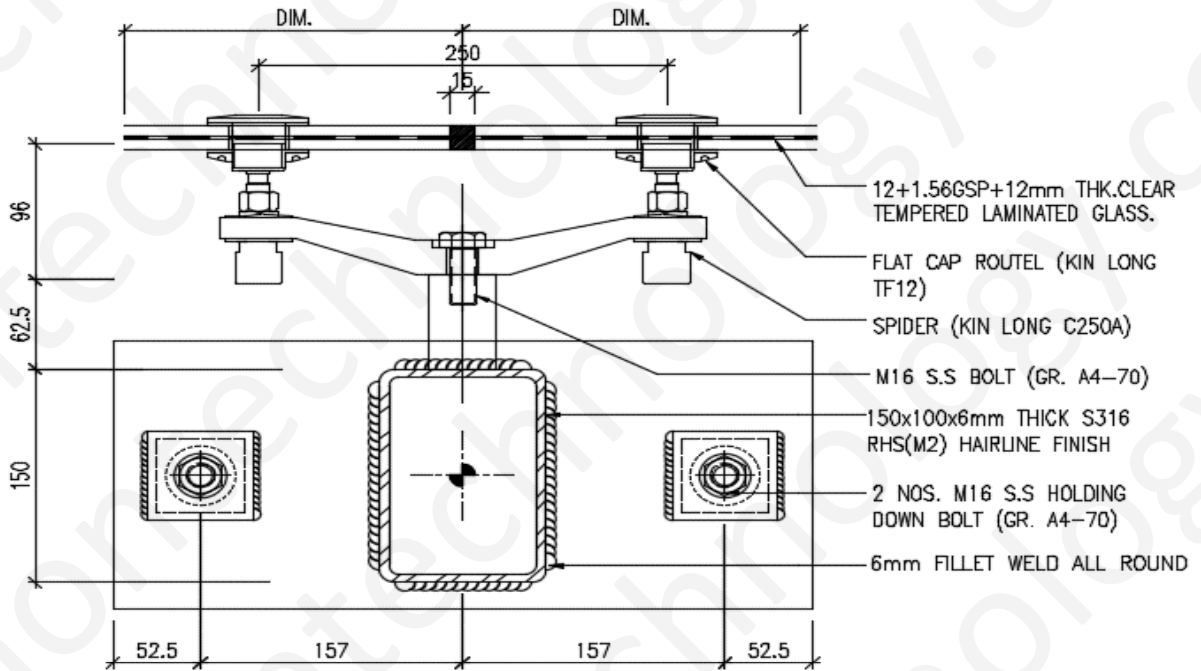

Vertical load = 9.493 kN (refer to item 5.1)

Shear load on each bolt = $9.493 / 2$
= 4.75 kN

Tensile area of M16 bolt = 156 mm²

Tensile strength of M16 bolt = 373 N/mm²

Shear strength of M16 bolt = 280 N/mm²

Shear capacity of bolt = $156 \times 280 / 1000$
= 43.68 kN
> 4.75 kN

O.K.