

# LED Neon flex

## User Manual

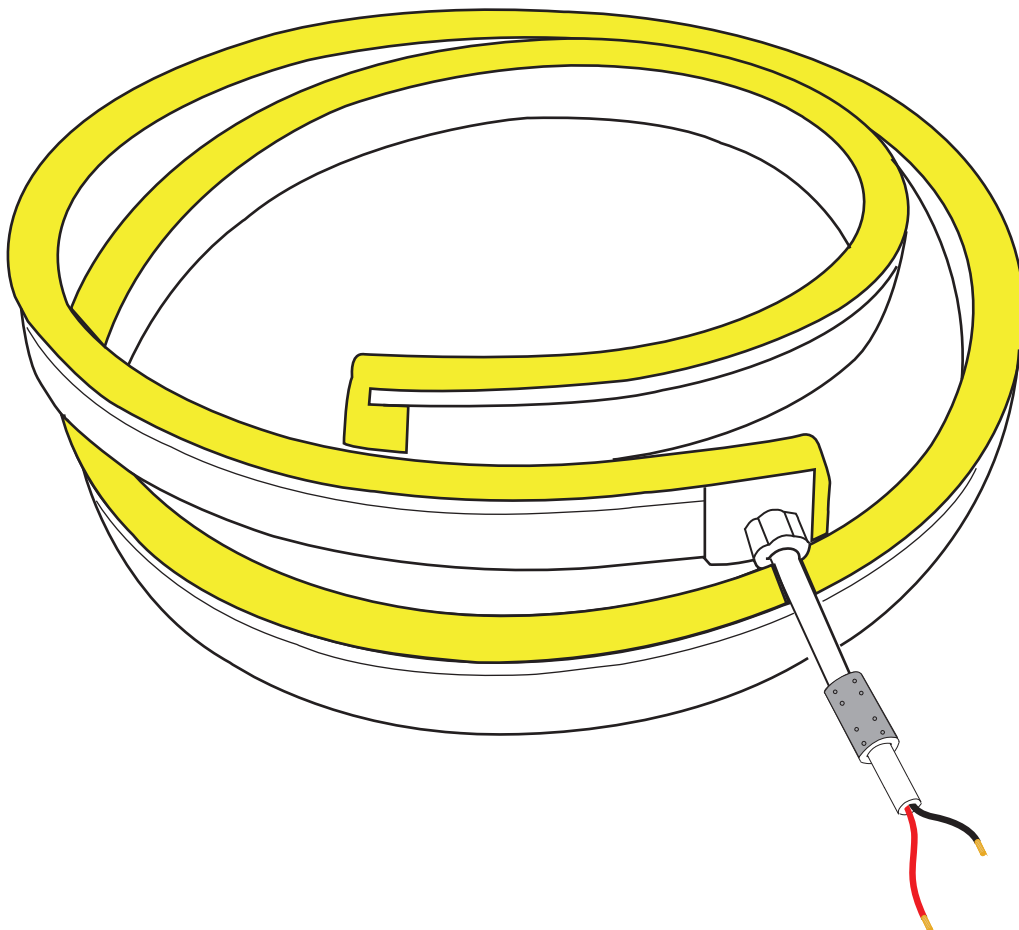

# Contents

1) Introduction.....	1
2) Product Overview.....	2
3) Installation Guide.....	4
4) Mounting Product.....	5
5) DIY screw connector kit assembly instruction.....	8
6) DIY snap connector kit assembly instruction.....	11
7) Electrical Connection.....	15
8) Connection Examples.....	17

# 1.Introduction

LED Neon Flex are bendable and highly durable linear LED solutions – suitable for both indoor and outdoor applications. To achieve a uniform and diffused light output, The LED Neon Flex range encapsulates LED strips with high-quality Epistar chips inside a flexible 40Z FPC. The protective casing prevents UV damage, is waterproof, as well as flame and solvent-resistant. We offer a range of dimensions and colour temperatures; depending on the environment our Neon LEDs can be mounted, recessed and semi-recessed.

LED neon flex can be divided with different bending direction between horizontal and vertical, also the shape and emitting beam angle are not the same.

This user manual is intended to cover as much detail as possible for this product, and great care has been taken to ensure this and the accuracy of the information contained within, however should additional information or clarification be required that is not covered within this manual or associated data sheets, or if there are any uncertainties regarding the installation and operation of this product, Distributor **MUST** be contacted before any work is carried out on the fixture or associated products.

## Horizontal Bending (Sideview emitting series)

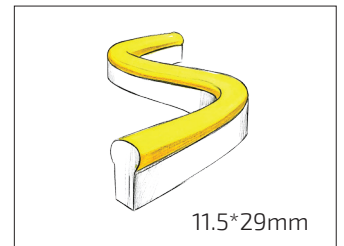
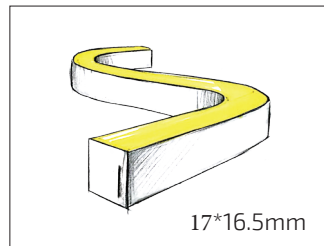
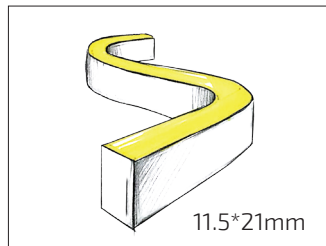
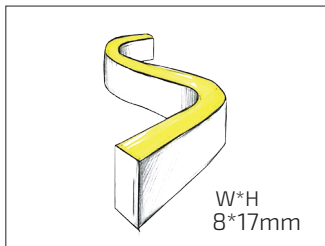

## Vertical Bending (Topview emitting series)

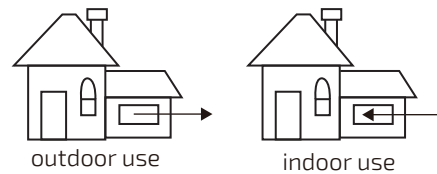
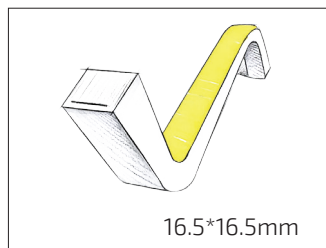
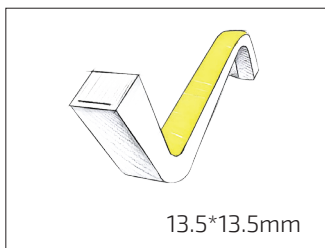

## Construction

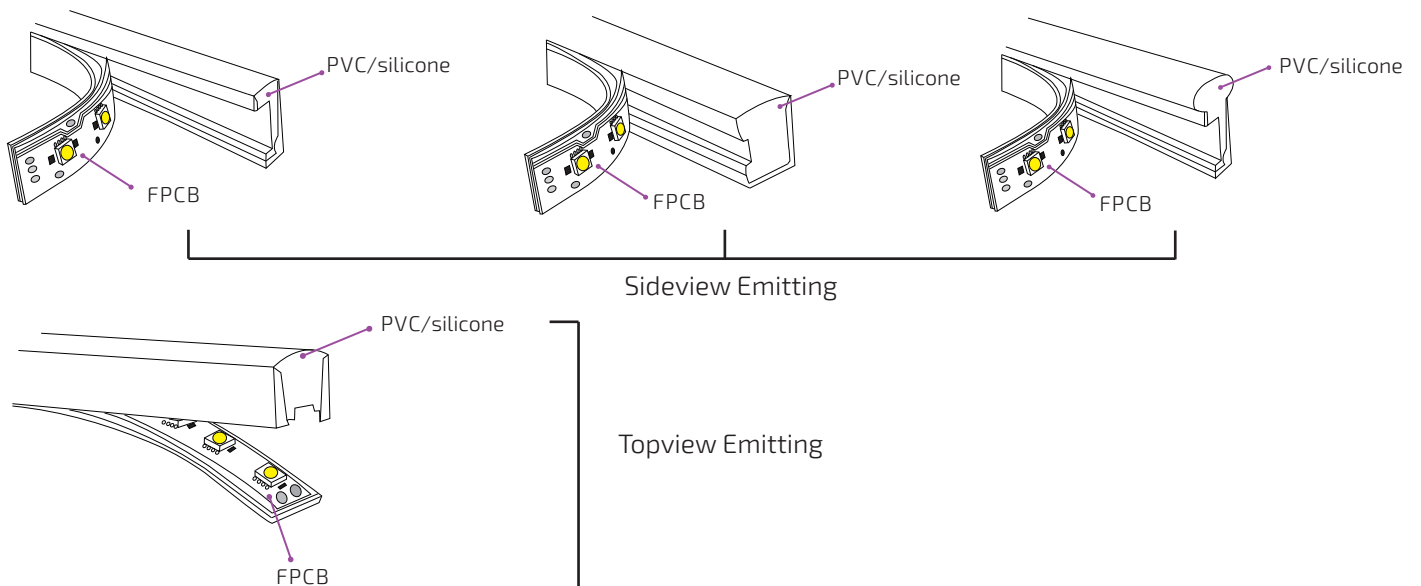

- UV Protected
- Class 2 Electrical
- Dirt Resistant
- CE Certificate
- Saltwater Resistant
- UL Certificate
- RoHS Certificate
- LM-80
- IK08
- Corrosion Resistant
- IP68 Ingress Protection
- One Bin

## 2. Product Overview

### Side flat shape Neon Flex (8\*17mm)

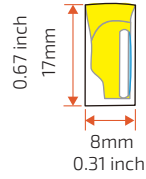

- Flat rectangular emission surface with 120-degree beam angle.
- The mini bend diameter of 8cm, suitable for led neon sign application.
- Available in static color including white in CCT ranging from 2200K-6500K. (Please refer to our datasheets specification for the exact color range)
- Color options include green, blue, red, pink, amber, orange.
- Dimmable with DALI, 0-10V, DMX/RDM, Triac control options.

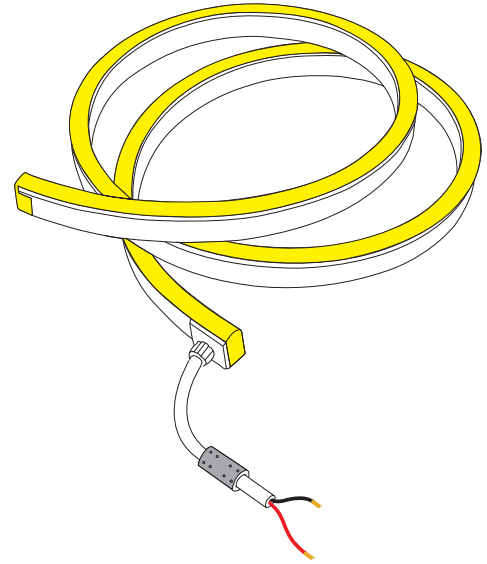

### Side flat shape Neon Flex (11.5\*21mm)

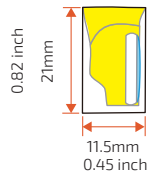

- Flat rectangular emission surface with 120-degree beam angle.
- 8 cm bend diameter dependant on variant
- Available in static color including white in CCT ranging from 2200K-6500K. (Please refer to our datasheets specification for the exact color range)
- Color options include RGB, RGBW, DW and Pixel.
- DALI, 0-10V, Triac DMX/RDM control options.

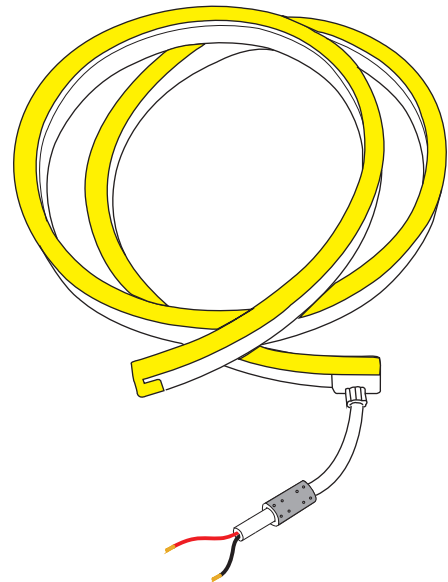

### Side flat shape Neon Flex (16.5\*16.5mm)

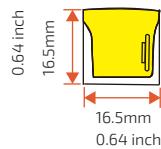

- Flat rectangular emission surface with 120-degree beam angle.
- The bend diameter of 12cm
- Available in static color including white in CCT ranging from 2200K-6500K. (Please refer to our datasheets specification for the exact color range)
- Color options include green, blue, red, pink, amber, orange.
- Dimmable with DALI, 0-10V, DMX, Triac.

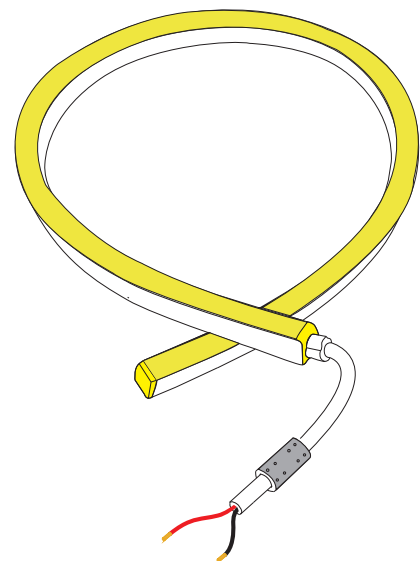



## Side Dome shape Neon Flex (11.5\*29mm)

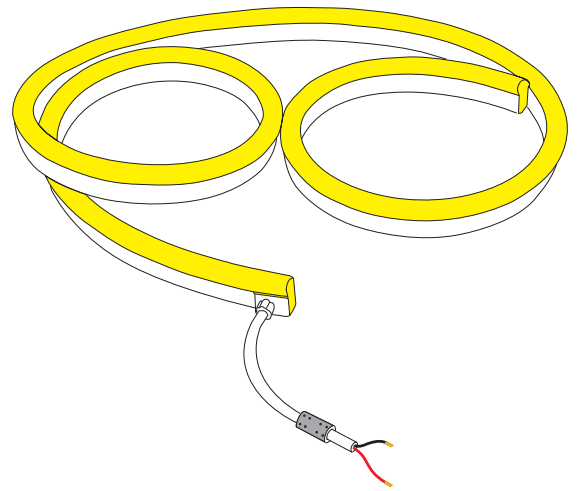
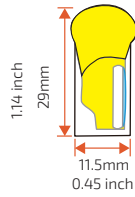

- Dome rectangular emission surface with 270-degree beam angle.
- The bend diameter of 8/12cm
- Available in static color including white in CCT ranging from 2200K-6500K. (Please refer to our datesheets specification for the exact color range)
- Color options include RGB, RGBW, DW and Pixel
- Dimmable with DALI, 0-10V, DMX, Triac.

## Top flat mini shape Neon Flex (13.5\*13.5mm)

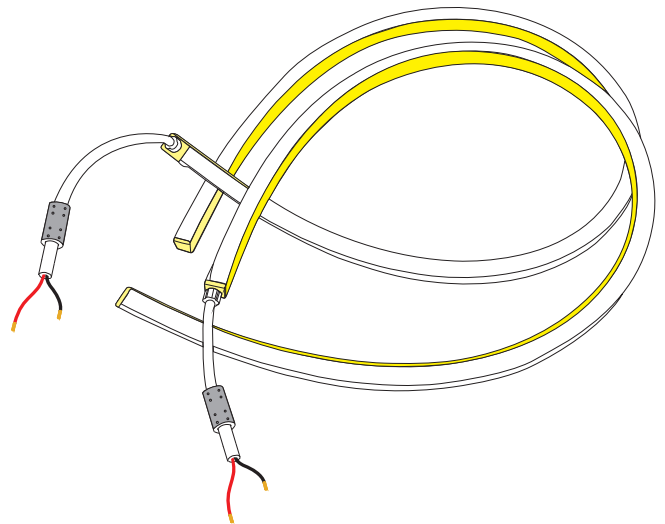
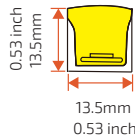

- Flat rectangular emission surface with 120-degree beam angle.
- 8cm bend diameter
- Available in static color including white in CCT ranging from 2200K-6500K. (Please refer to our datesheets specification for the exact color range)
- Color options include green, blue, red, pink, amber, orange.
- DALI, 0-10V, DMX, Triac controller options

## Side flat shape Neon Flex (16.5\*16.5mm)

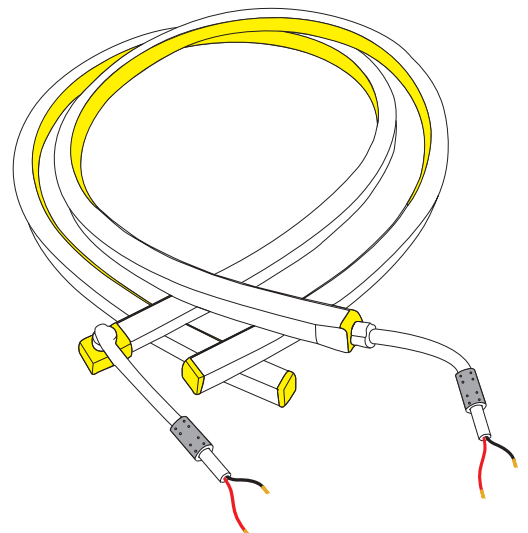
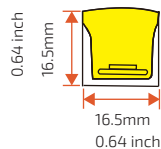

- Flat rectangular emission surface with 120-degree beam angle.
- 12cm bend diameter
- Available in static color including white in CCT ranging from 2200K-6500K. (Please refer to our datesheets specification for the exact color range)
- Color options include RGB, RGBW, DW and Pixel
- DALI, 0-10V, DMX, Triac controller options

## 3. Installation Guide

This product left the place of manufacture in perfect condition. In order to maintain this condition and for safe operation, the user must always follow the instructions and safety warnings described in this user manual.

### Safety Warning! General

- This product must be installed by a qualified and competent professional.
- When working on the fixture, heat resistant gloves should be worn to provide adequate user protection.
- Do not work on the product with wet hands.
- Always disconnect the power supply before attempting to maintain or service the equipment.
- Always operate the equipment as described in this user manual.
- Do not stand close to the equipment and stare directly into the LED light source.
- Make sure that all parts of the equipment are kept clean and free of dust which should be carried out as part of a maintenance cycle that's appropriate for the installation location of the product.
- When transferring the product, it is advisable to use the original packaging in which the product left the factory.
- Shields, lenses, ultraviolet screens and pressure release valves should be changed if they have become damaged to such an extent that their effectiveness is impaired.
- The lamp (LED) should be changed if it has become damaged or thermally deformed.
- The power supply (PSU), DMX/RDM driver and LED drivers should be changed if they fail to operate.

### Installation

- A minimum distance of 0.5m must be maintained between the equipment and any combustible surface. The mounting surface must not be combustible.
- Always ensure the supporting structure is a flat and solid surface and can support the weight of the product and any additional wind or shear force. The supporting structure must be capable for the installation of luminaires, and advice must be taken from an appropriately qualified and competent person to verify proposed mounting positions and surfaces.
- Always make sure that the equipment is installed securely and ensure all safety anchors are installed.
- The product must be installed within well-ventilated areas.
- The Earth wire MUST ALWAYS be connected.
- Local electrical and building regulations must be followed. If in doubt, please contact support distributor
- Avoid shaking or strong impacts to any part of the equipment.
- Always make sure that the power and data connections are connected correctly and securely. If there is any malfunction of the equipment, contact your local distributor immediately.
- This fixture should not be buried.

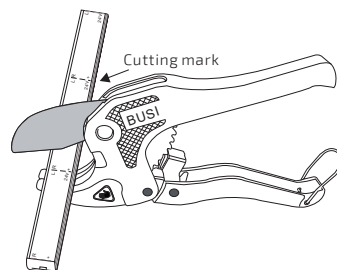

This user manual is intended to cover as much detail as possible for this product, and great care has been taken to ensure this and the accuracy of the information contained within, however should additional information or clarification be required that is not covered within this manual or associated data sheets, or if there are any uncertainties regarding the installation and operation of this product, Distributor MUST be contacted before any work is carried out on the fixture or associated products.

FAILURE TO COMPLY WITH THIS MANUAL AND LOCAL ELECTRICAL AND CONSTRUCTION REGULATIONS MAY RESULT IN SERIOUS INJURY OR EVEN DEATH - ALWAYS ISOLATE POWER BEFORE WORKING ON ELECTRICAL PRODUCTS AND ENSURE ADEQUATE MEASURES ARE TAKEN TO MECHANICALLY SUPPORT FIXTURES AT ALL TIMES.

### Specific Installation

- Although this product does not generate a great amount of heat, it is recommended that you do not cover or conceal it.
- Do not route the product through walls, doors, windows, or building structures.
- Do not roll out the product onto rough surfaces or over sharp corners. This will scratch the PVC /silicone optics and damage the finish of the product.
- Do not use the product if :
  - The outer PVC jacket is damaged
  - There are loose electrical connections
  - The wires are visible without insulation.
- Do not secure the product with staples, nails, or alike that might damage the insulation or PVC/silicone material.
- Do not install the product on/in places where it is subject to continuous flexing.
- Do not operate/run the product in temperatures exceeding 55C.
- Do not operate the product over the specified voltage or LED life degradation will be greatly increased.
- Do not leave any part of the product unsecured.
- Constant movement over time from weather can cause damage.
- Do not reverse polarity when connecting from both ends. This will damage the internal PCB. Always test connections with a multi-meter before applying power.
- Do not energise the product whilst in packaging.
- The product can be cut only where marked. Look for the "Dotted Line" or "Cutting Mark". A cut section must have the appropriate IP rated cap flex accessory to maintain IP ratings.
- Cutting outside of the specified mark will damage the light.
- Do not cut while the LED flex neon is connected to power.
- Do not install in human inhabited pools.
- During installation, violent pulling and bending are prohibited.
- Must always be used with an electrical isolation transformer providing SELV (safety extra low voltage).
- **Do not cut off the cable wire between the waterproof metal ferrule and connector.**



### Caution, risk of electric shock



The light source and other electronic components contained in this luminaire shall only be replaced by your distributor service agent.

## 4. Mounting Product

Led neon flex is a highly durable product but must be installed in accordance to the pictures shown below, which indicate the minimum bending parameters as well as the correctly bending direction for each specific variant of models

### Side flat and side round shape neon flex

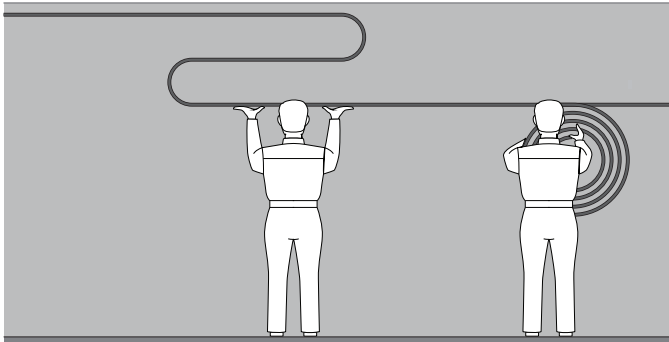

LED neon flex must be installed by at least 2 people, who can support the product in various locations as shown. During installation, care should be taken to ensure the bending radius of is not exceeded.

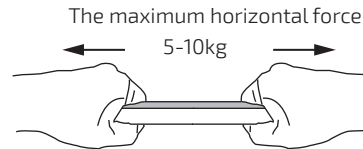

Light profile

Bending direction

Min. bending diameter

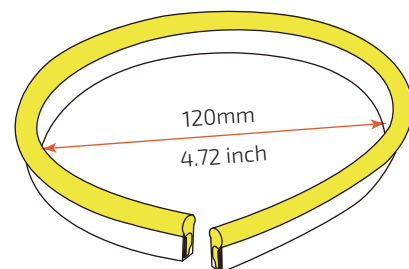
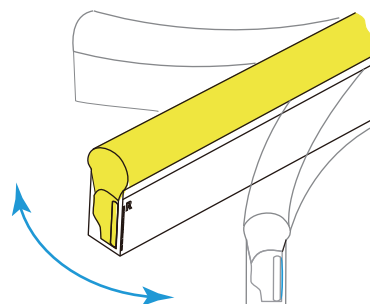
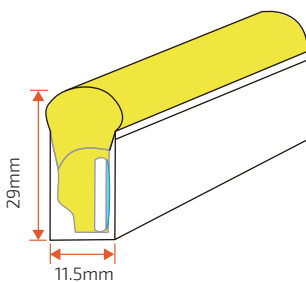
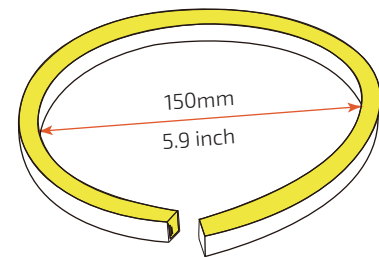
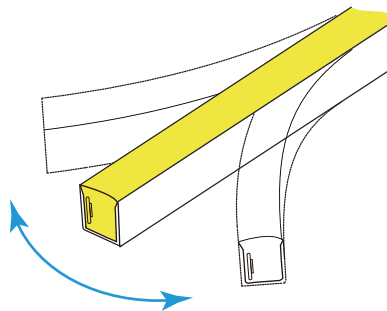
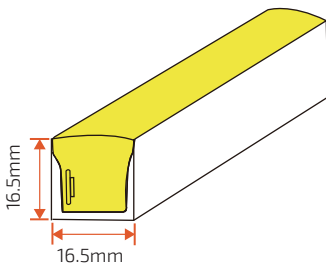
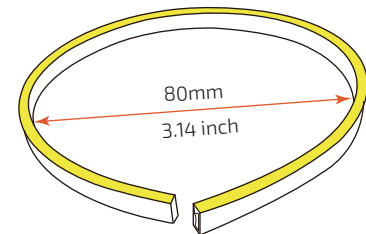
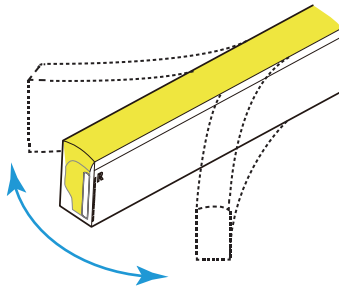
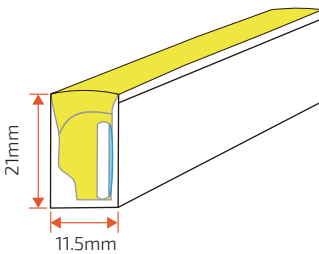
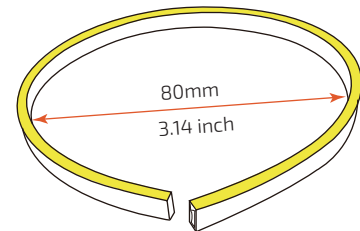
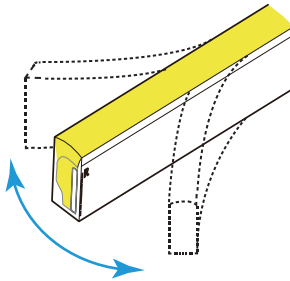
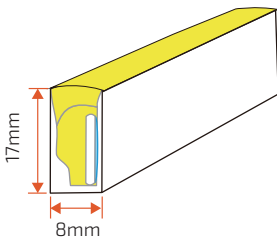

Led neon flex is a highly durable product but must be installed in accordance to the pictures shown below, which indicate the minimum bending parameters as well as the correctly bending direction for each specific variant of models

## Top flat shape neon flex

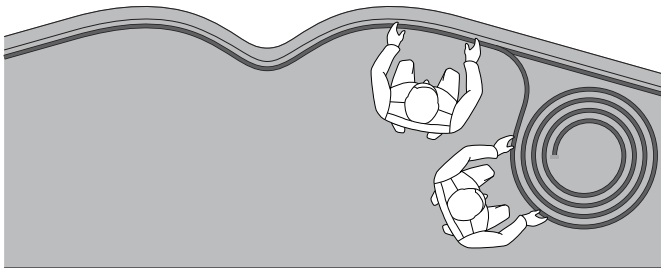

LED neon flex must be installed by at least 2 people, who can support the product in various locations as shown. During installation, care should be taken to ensure the bending radius of is not exceeded.

Light profile

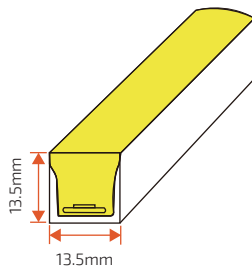

Bending direction

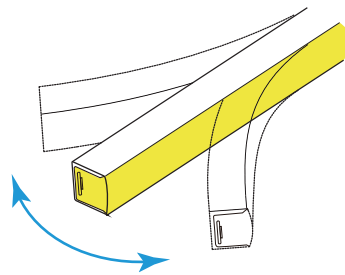

Min. bending diameter

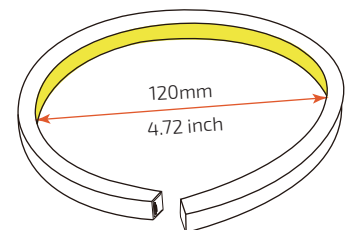
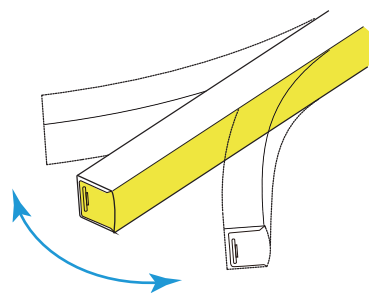
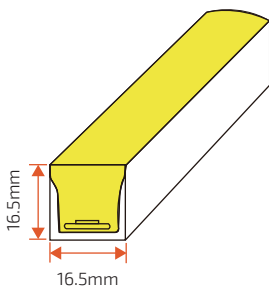
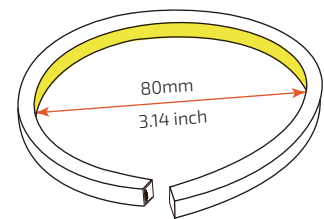

### General DO NOTS

The images give indication as to what is not acceptable as an intended installation or during installation of other fixing methods

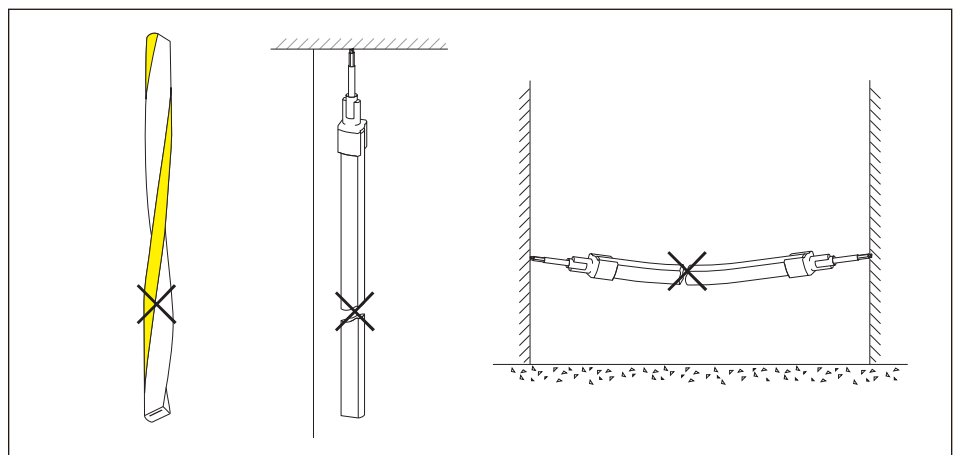

## General mounting

LED neon flex can be fastened to surfaces using appropriate accessories available from distributor. Please refer to data sheets or contact technical support for a copy. The use of glues and resins as fixing agents should be avoided. Use of glues and resins may invalidate the warranty of the product, unless its use is agreed in writing by distributor as part of a detailed project specification.

The images indicate one type of fixing available in the accessories range. The different fixings serve obvious purposes, however when in doubt technical support should be contacted.

Quantities of accessories and fixings are dependent on the type and its effect on the variant it's being used with. Care should be taken to ensure drooping is avoided, and to ensure that is fastened adequately to avoid stresses on itself.

The aluminum mounting piece of IP67 front connector and end cap should keep at least 10mm space apart from aluminum channel when making installation.

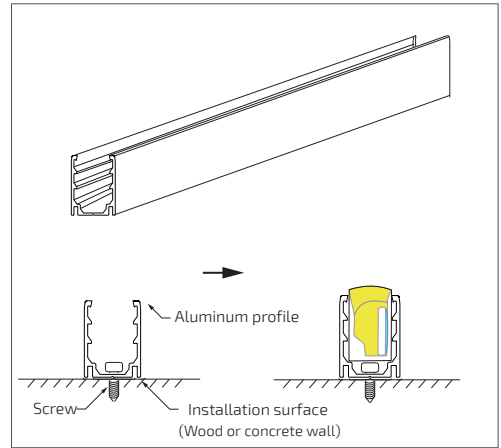
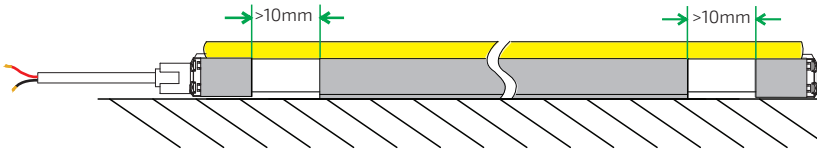

Press the flex light into mounted aluminum channel in one direction.

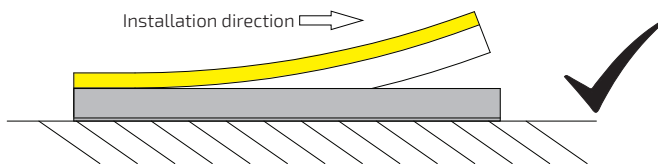

Incorrect installation like below picture could lead to light failure.

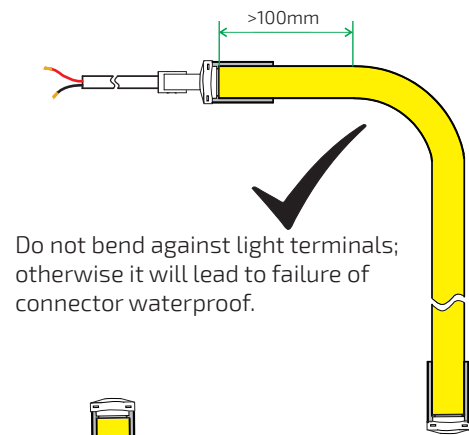
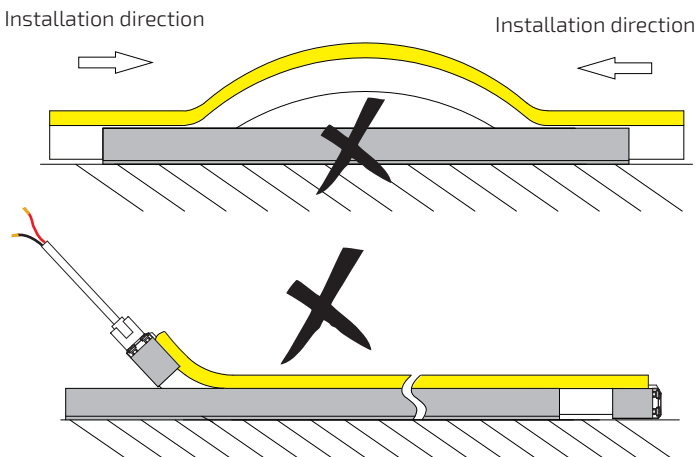

Do not bend against light terminals; otherwise it will lead to failure of connector waterproof.

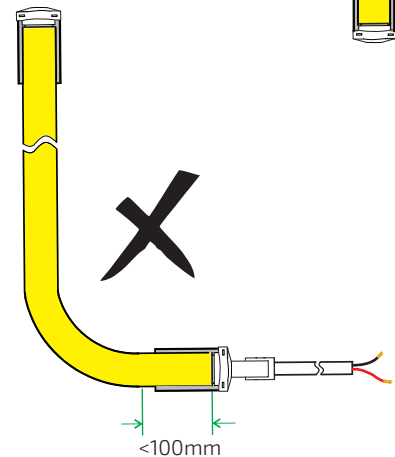

Ensure the feeding cable not bear force, keep the head 10mm in natural loose.

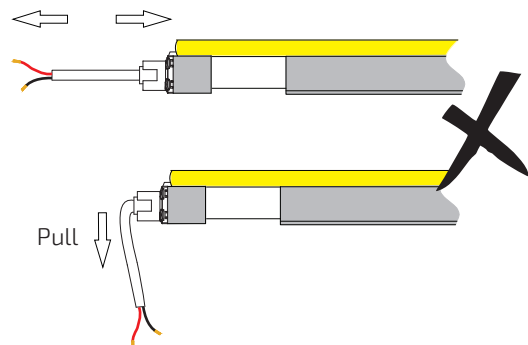
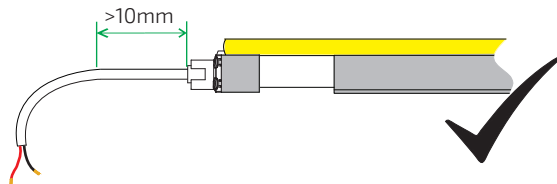

Mount the cable junction in hermetic enclosure like waterproof junction box in outdoor application.

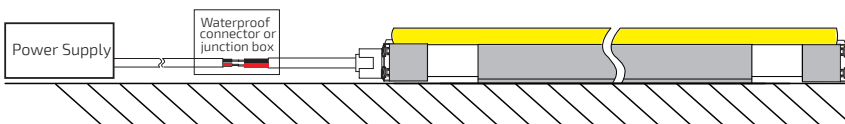

## 5. DIY Screw Connector Kit Assembly Instruction

The kit can be installed and link up with power supply to light up the neon flex after you have measured the exact length in your project, this can help you easily do it by yourself below the detailed assembly instruction. With the capability of IP67, the neon flex also can be used both outdoor and indoor.

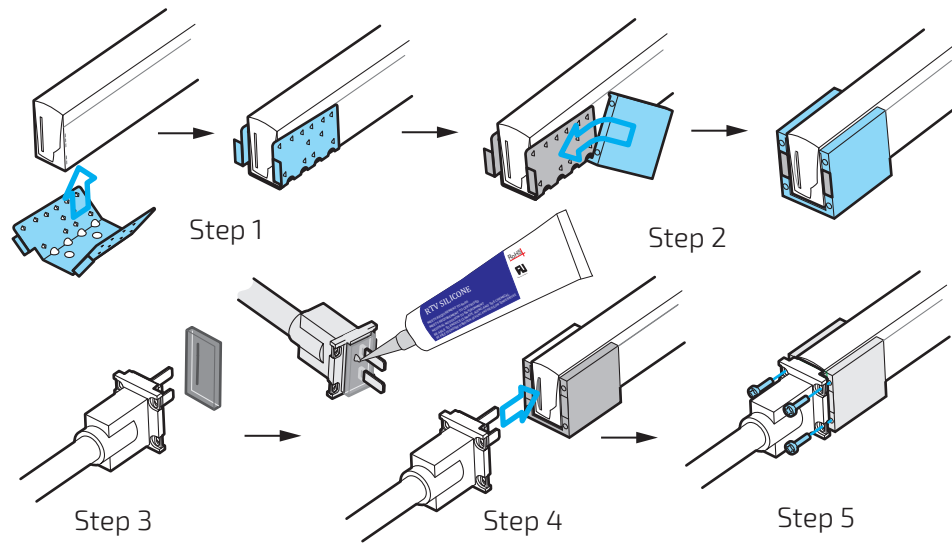
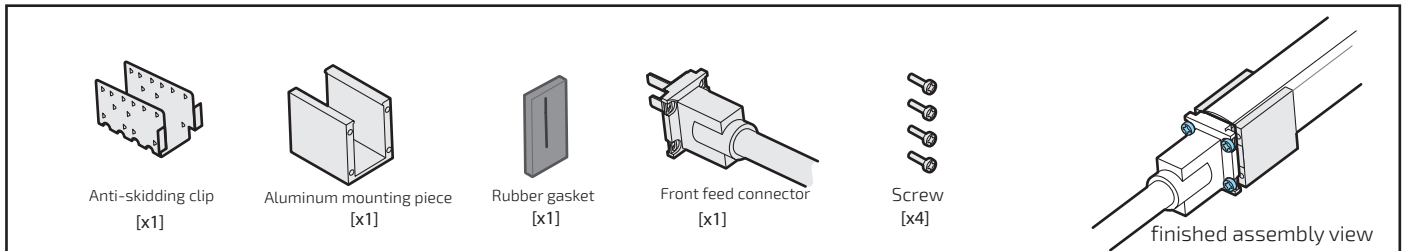

DIY Screw Front connector kit Assembly instruction

### Step 1

Place the anti-skidding clip on the very end of the tubing with the 2 tiny tabs that are pointing inwards still touching the end of the material and crimp in place.

### Step 2

Line up the aluminum mounting piece so the screw hole face the plug and slide on over the anti-skidding clip.

### Step 3

Insert the rubber gasket along with slit into the pin of the front feed connector, put 100% clear silicone on the surface of the rubber gasket.

### Step 4

Carefully insert the pins of the front feed connector into the gap created behind the FPCB.

### Step 5

Screw the front feed connector to the aluminum mounting piece

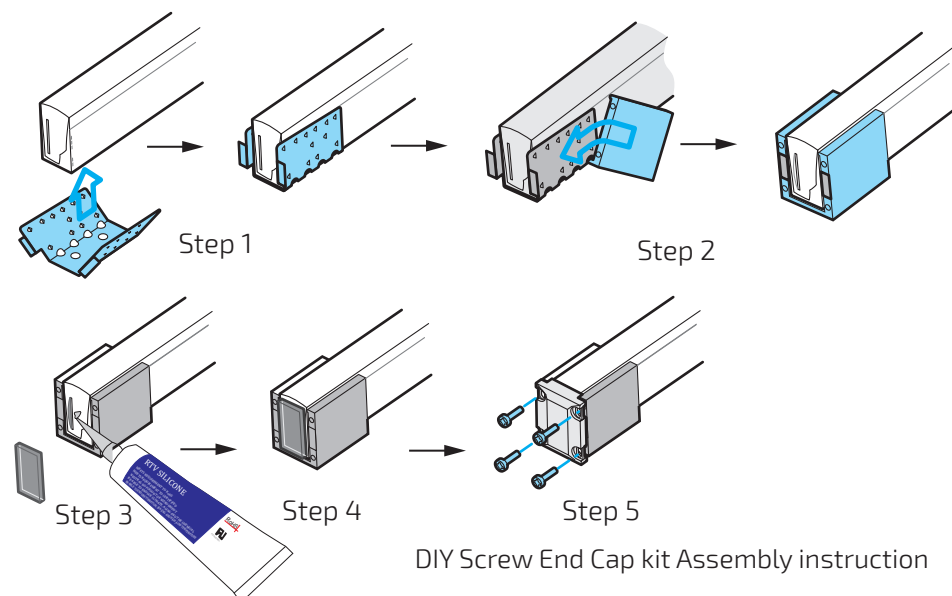
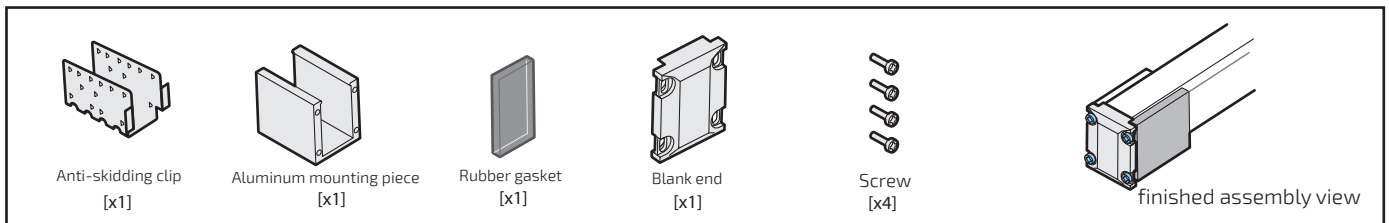

DIY Screw End Cap kit Assembly instruction

### Step 1

Place the anti-skidding clip on the very end of the tubing with the 2 tiny tabs that are pointing inwards still touching the end of the material and crimp in place.

### Step 2

Line up the aluminum mounting piece so the screw hole face the plug and slide on over the anti-skidding clip.

### Step 3

Apply 100% clear silicone onto the end face of led neon flex

### Step 4

Place the rubber gasket squarely onto the end face of led neon flex.

### Step 5

Screw the blank end to the aluminum mounting piece.

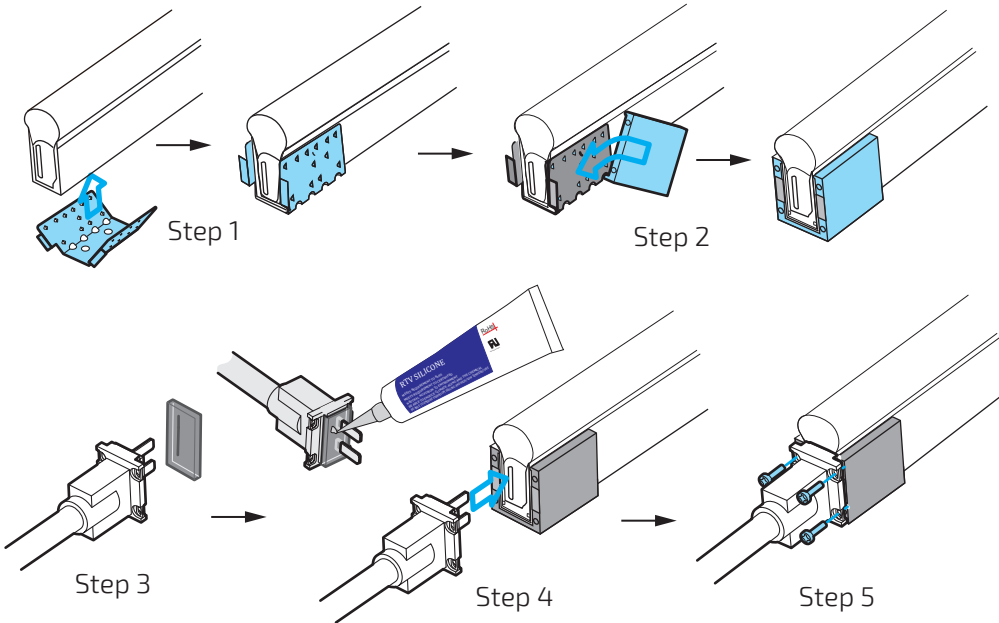
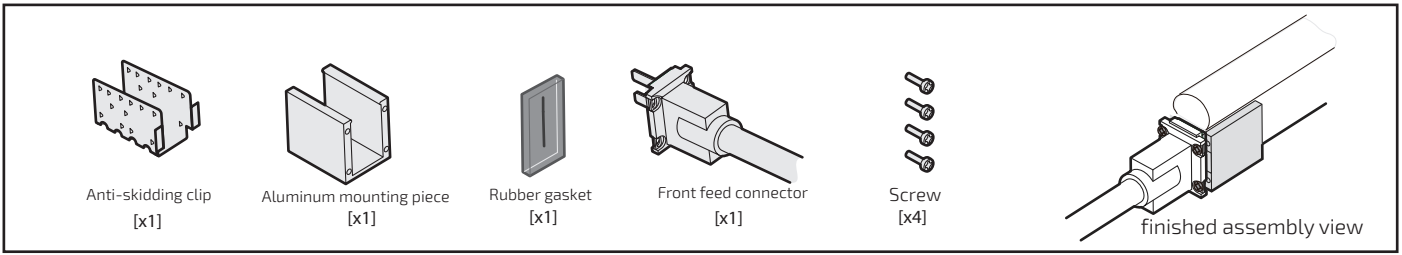

**Step 1**

Place the anti-skidding clip on the very end of the tubing with the 2 tiny tabs that are pointing inwards still touching the end of the material and crimp in place.

**Step 2**

Line up the aluminum mounting piece so the screw hole face the plug and slide on over the anti-skidding clip.

**Step 3**

Insert the rubber gasket along with slit into the pin of the front feed connector, put 100% clear silicone on the surface of the rubber gasket.

**Step 4**

Carefully insert the pins of the front feed connector into the gap created behind the FPCB.

**Step 5**

Screw the front feed connector to the aluminum mounting piece

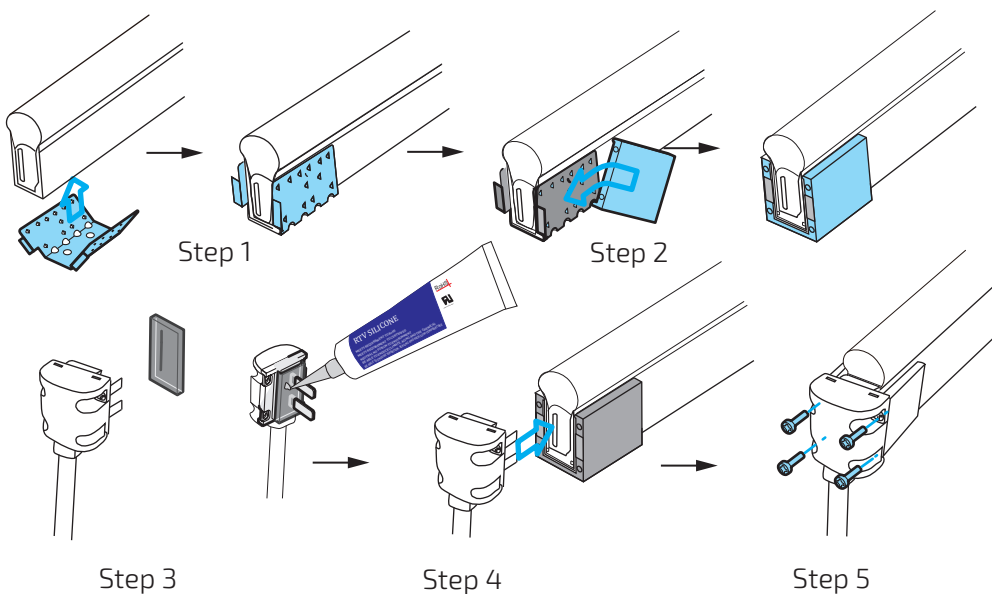
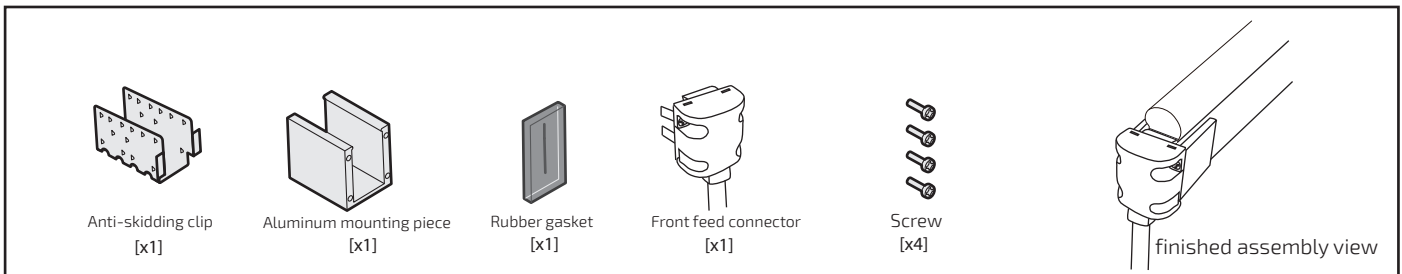

**Step 1**

Place the anti-skidding clip on the very end of the tubing with the 2 tiny tabs that are pointing inwards still touching the end of the material and crimp in place.

**Step 2**

Line up the aluminum mounting piece so the screw hole face the plug and slide on over the anti-skidding clip.

**Step 3**

Insert the rubber gasket along with slit into the pin of the front feed connector, put 100% clear silicone on the surface of the rubber gasket.

**Step 4**

Carefully insert the pins of the front feed connector into the gap created behind the FPCB.

**Step 5**

Screw the front feed connector to the aluminum mounting piece



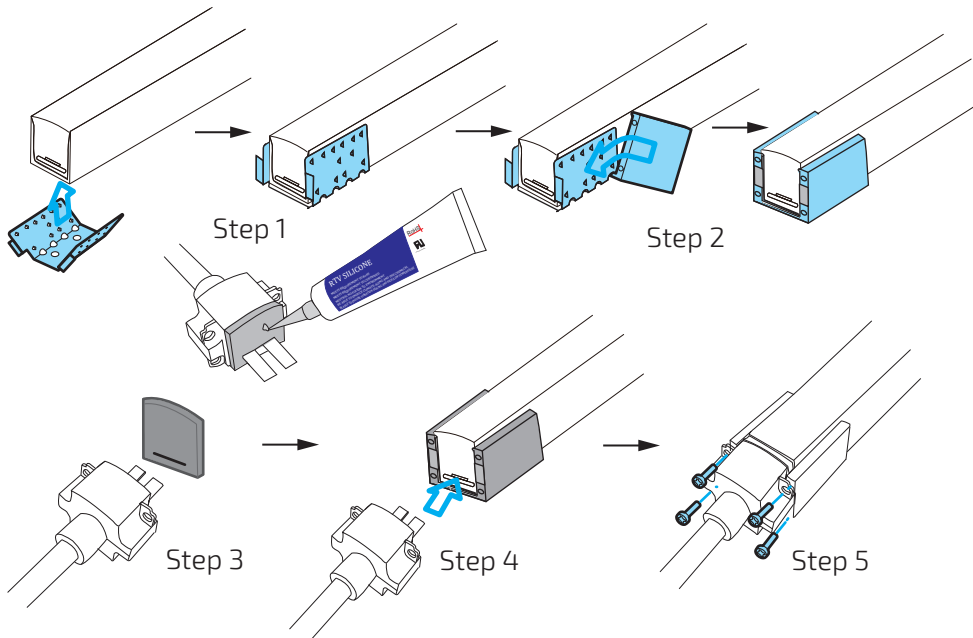
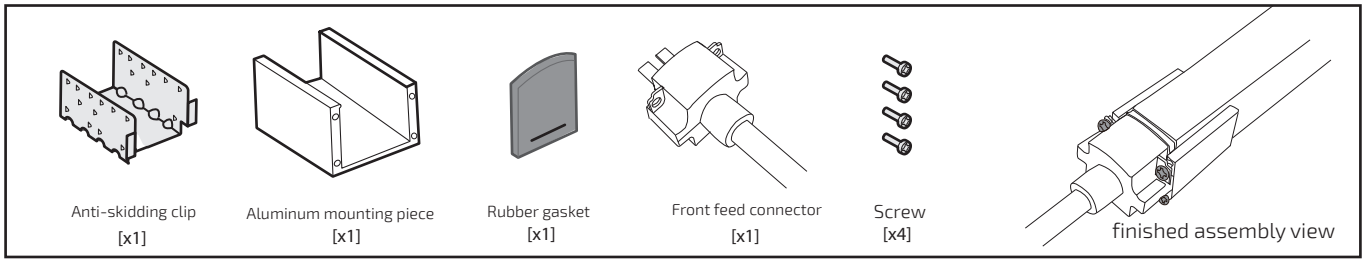

**Step 1**

Place the anti-skidding clip on the very end of the tubing with the 2 tiny tabs that are pointing inwards still touching the end of the material and crimp in place.

**Step 2**

Line up the aluminum mounting piece so the screw hole face the plug and slide on over the anti-skidding clip.

**Step 3**

Insert the rubber gasket along with slit into the pin of the front feed connector, put 100% clear silicone on the surface of the rubber gasket.

**Step 4**

Carefully insert the pins of the front feed connector into the gap created behind the FPCB.

**Step 5**

Srew the front feed connector to the aluminum mounting piece

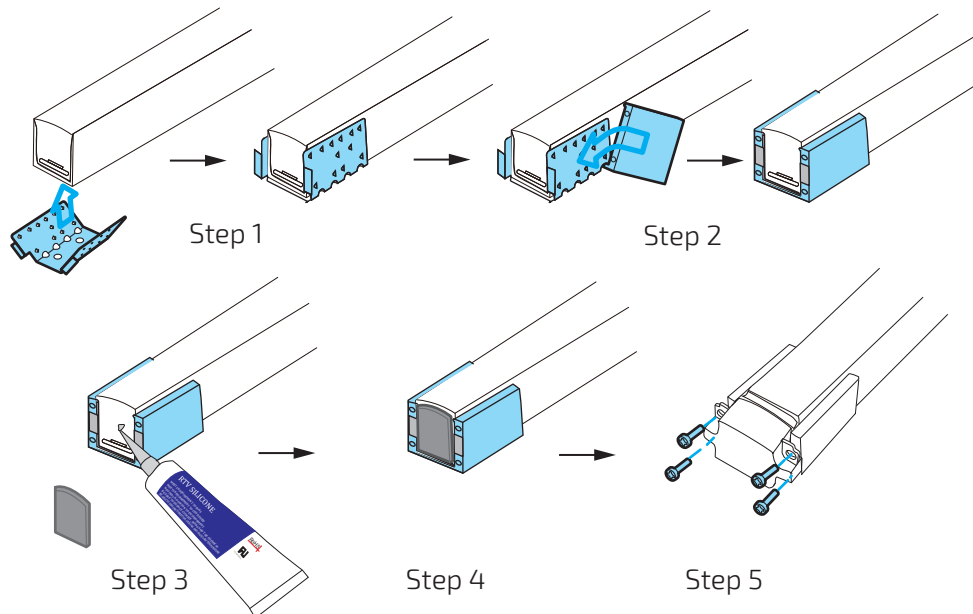
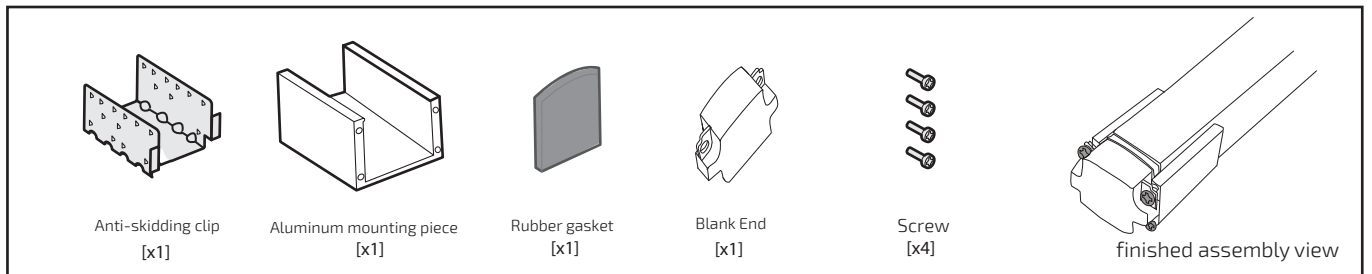

**Step 1**

Place the anti-skidding clip on the very end of the tubing with the 2 tiny tabs that are pointing inwards still touching the end of the material and crimp in place.

**Step 2**

Line up the aluminum mounting piece so the screw hole face the plug and slide on over the anti-skidding clip.

**Step 3**

Apply 100% clear silicone onto the end face of led neon flex

**Step 4**

Place the rubber gasket squarely onto the end face of led neon flex.

**Step 5**

Srew the blank end to the aluminum mounting piece.



## 6. DIY Snap Connector Kit Assembly Instruction

The snap kit can be easily installed than screw kit without any tool, it also has the same waterproof function of IP67. Linked up with power supply to light up the neon flex after you have measured the exact length in your project, this can help you easily do it by yourself below the detailed assembly instruction.

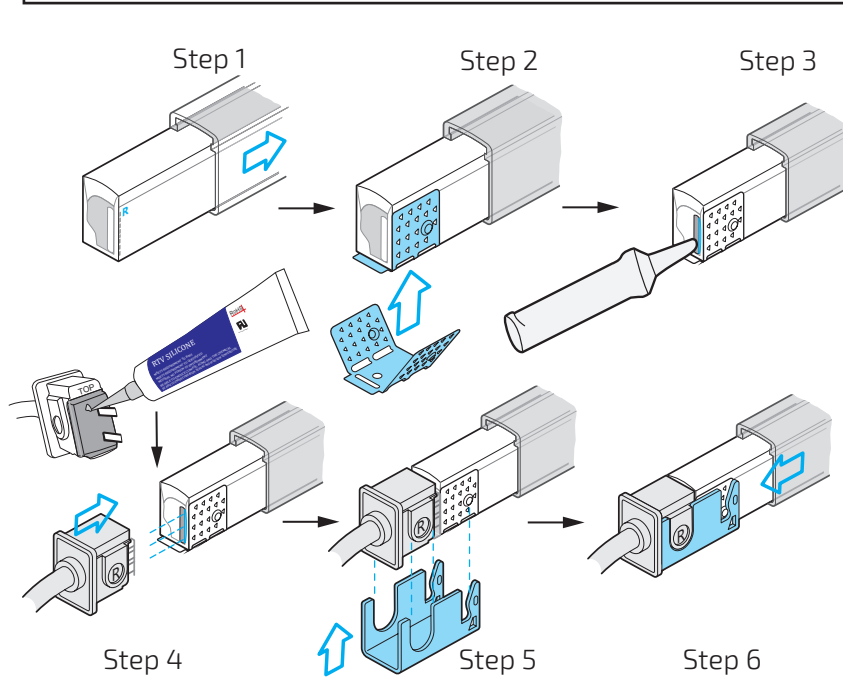
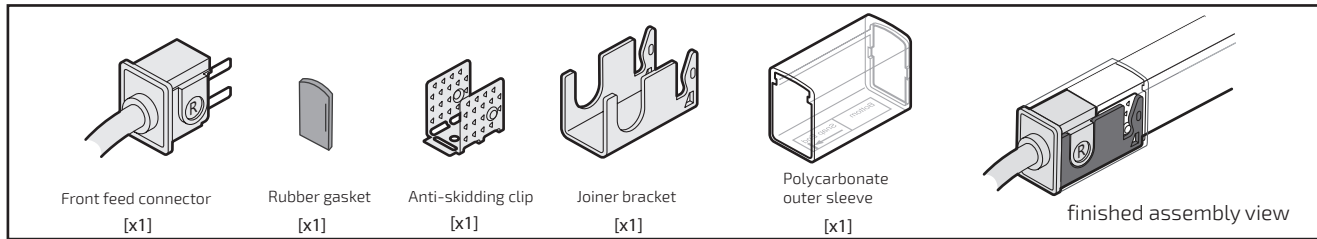

- Step 1**  
Let neon flex goes through polycarbonate outer sleeve, printed instruction aligns with the 'Snap End' arrow points in the direction of the front feed connector.
- Step 2**  
Place the anti-skidding clip on the very end of the neon with the 2 tiny tabs that are pointing inwards still touching the end of material and crimp in place.
- Step 3**  
Place the tip of the assistant tool against the outer side of the internal circuit board within the neon flex. Carefully push the tool into the neon flex (max. depth of 12.5mm) and creates a small cavity in the flexible material on the outer side of the circuit board.
- Step 4**  
Insert rubber gasket into the pins and apply 100% clear silicone on the surface of it. Align the front feed connector with the cut end part and carefully push its pins into the gaps.
- Step 5**  
Gently yet firmly push the joiner bracket onto the front feed connector assembly. The two parts close together and eventually lock them into place.
- Step 6**  
Slide the polycarbonate outer sleeve and butts up to the flange of the front connector.

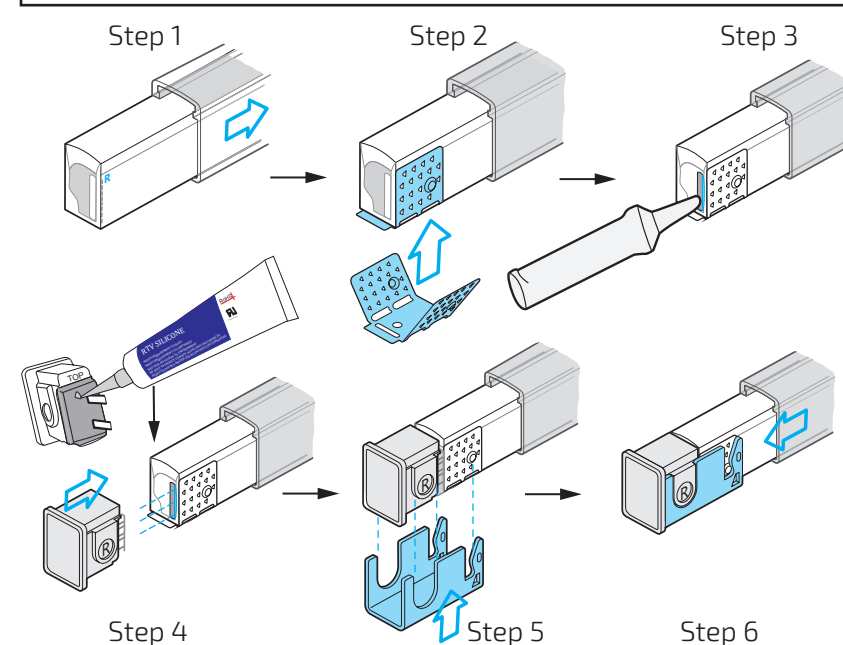
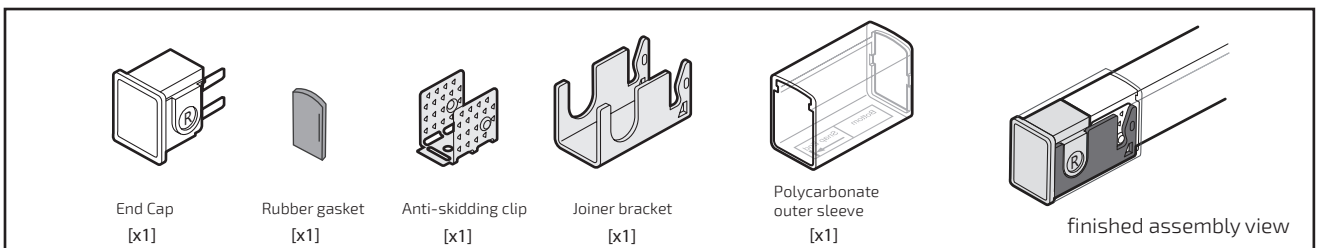

- Step 1**  
Let neon flex goes through polycarbonate outer sleeve, printed instruction aligns with the 'Snap End' arrow points in the direction of end cap.
- Step 2**  
Place the anti-skidding clip on the very end of the neon with the 2 tiny tabs that are pointing inwards still touching the end of material and crimp in place.
- Step 3**  
Place the tip of the assistant tool against the outer side of the internal circuit board within the neon flex. Carefully push the tool into the neon flex (max. depth of 12.5mm) so that it creates a small cavity in the flexible material on the outer side of the circuit board.
- Step 4**  
Insert rubber gasket into the pins and apply 100% clear silicone on the surface of it. Align end cap with the cut end part and carefully push its pins into the gaps.
- Step 5**  
Gently yet firmly push the joiner bracket onto the end cap assembly. The two parts close together and eventually lock them into place.
- Step 6**  
Slide the polycarbonate outer sleeve and butts up to the flange of end cap

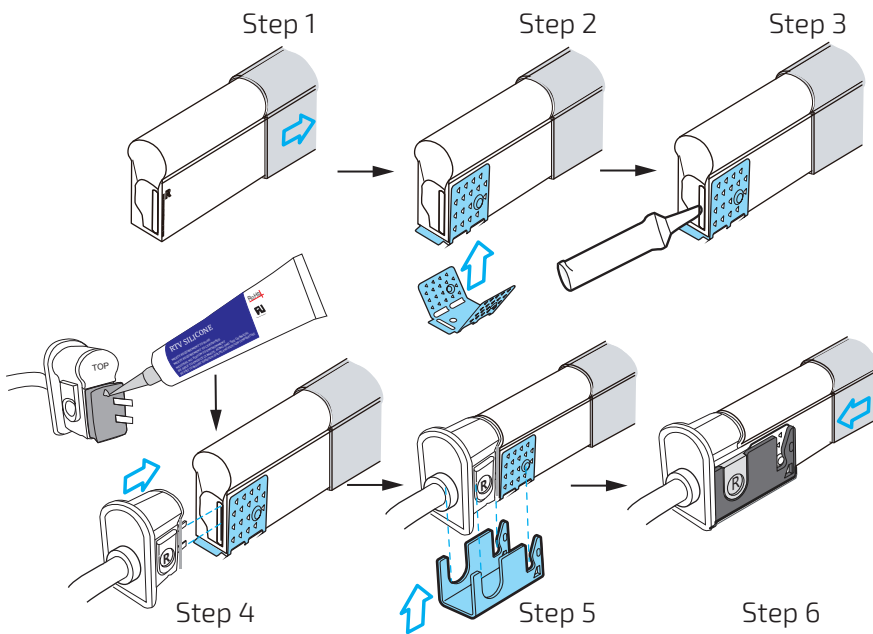
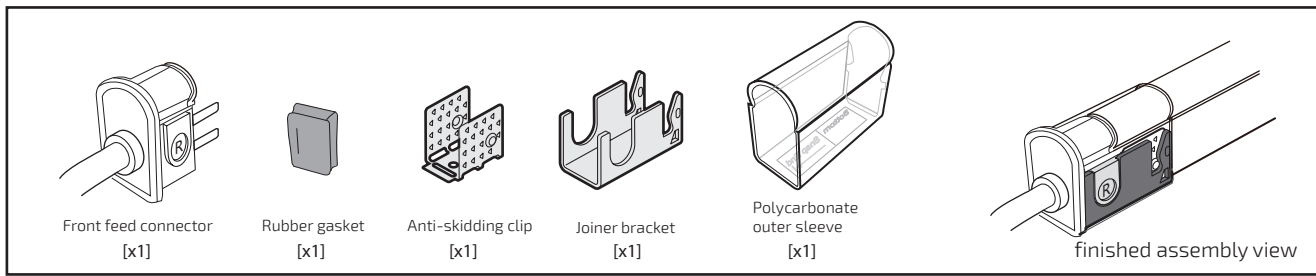

**Step 1**

Let neon flex goes through polycarbonate outer sleeve, printed instruction aligns with the 'Snap End' arrow points in the direction of the front feed connector.

**Step 2**

Place the anti-skidding clip on the very end of the neon with the 2 tiny tabs that are pointing inwards still touching the end of material and crimp in place.

**Step 3**

Place the tip of the assistant tool against the outer side of the internal circuit board within the neon flex. Carefully push the tool into the neon flex (max. depth of 12.5mm) and creates a small cavity in the flexible material on the outer side of the circuit board.

**Step 4**

Insert rubber gasket into the pins and apply 100% clear silicone on the surface of it. Align the front feed connector with the cut end part and carefully push its pins into the gaps.

**Step 5**

Gently yet firmly push the joiner bracket onto the front feed connector assembly. The two parts close together and eventually lock them into place.

**Step 6**

Slide the polycarbonate outer sleeve and butts up to the flange of the front connector.

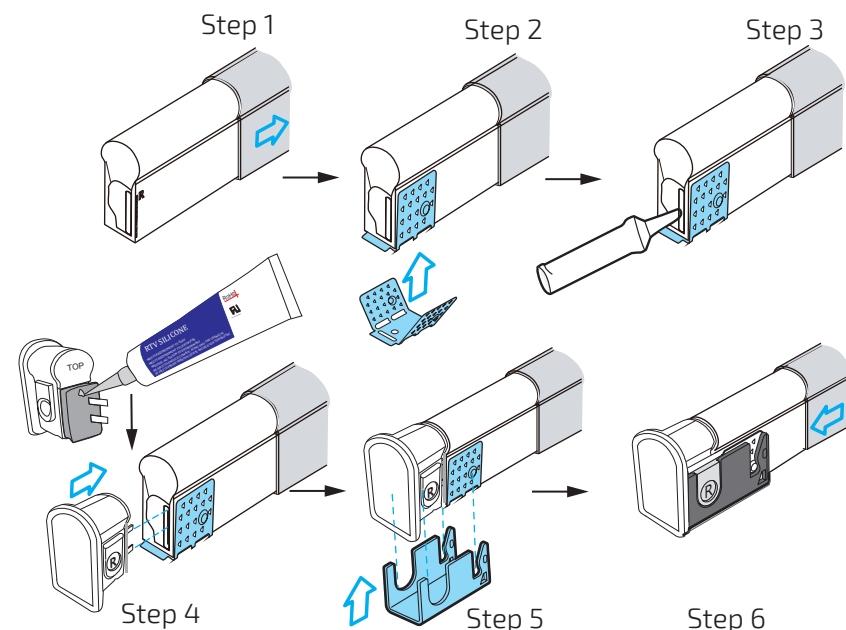
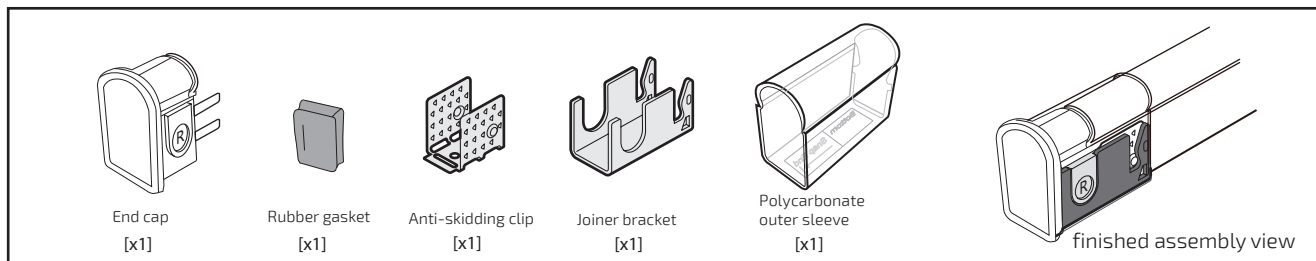

**Step 1**

Let neon flex goes through polycarbonate outer sleeve, printed instruction aligns with the 'Snap End' arrow points in the direction of end cap.

**Step 2**

Place the anti-skidding clip on the very end of the neon with the 2 tiny tabs that are pointing inwards still touching the end of material and crimp in place.

**Step 3**

Place the tip of the assistant tool against the outer side of the internal circuit board within the neon flex. Carefully push the tool into the neon flex (max. depth of 12.5mm) so that it creates a small cavity in the flexible material on the outer side of the circuit board.

**Step 4**

Insert rubber gasket into the pins and apply 100% clear silicone on the surface of it. Align end cap with the cut end part and carefully push its pins into the gaps.

**Step 5**

Gently yet firmly push the joiner bracket onto the end cap assembly. The two parts close together and eventually lock them into place.

**-Step 6**

Slide the polycarbonate outer sleeve and butts up to the flange of end cap.

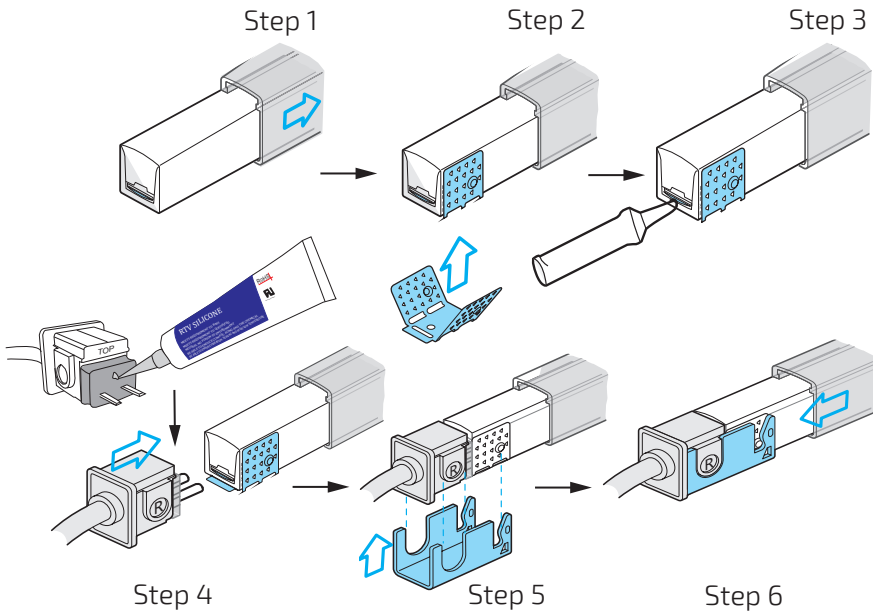
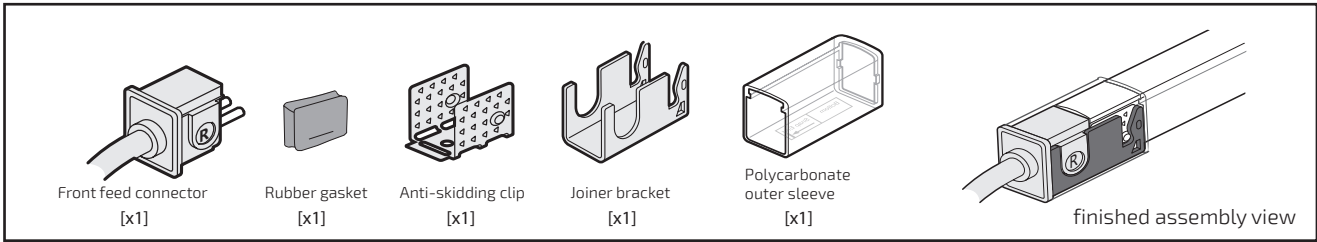

**Step 1**

Let neon flex goes through polycarbonate outer sleeve, printed instruction aligns with the 'Snap End' arrow points in the direction of the front feed connector.

**Step 2**

Place the anti-skidding clip on the very end of the neon with the 2 tiny tabs that are pointing inwards still touching the end of material and crimp in place.

**Step 3**

Place the tip of the assistant tool against the outer side of the internal circuit board within the neon flex. Carefully push the tool into the neon flex (max. depth of 12.5mm) and creates a small cavity in the flexible material on the outer side of the circuit board.

**Step 4**

Insert rubber gasket into the pins and apply 100% clear silicone on the surface of it. Align the front feed connector with the cut end part and carefully push its pins into the gaps.

**Step 5**

Gently yet firmly push the joiner bracket onto the front feed connector assembly. The two parts close together and eventually lock them into place.

**Step 6**

Slide the polycarbonate outer sleeve and butts up to the flange of the front connector.

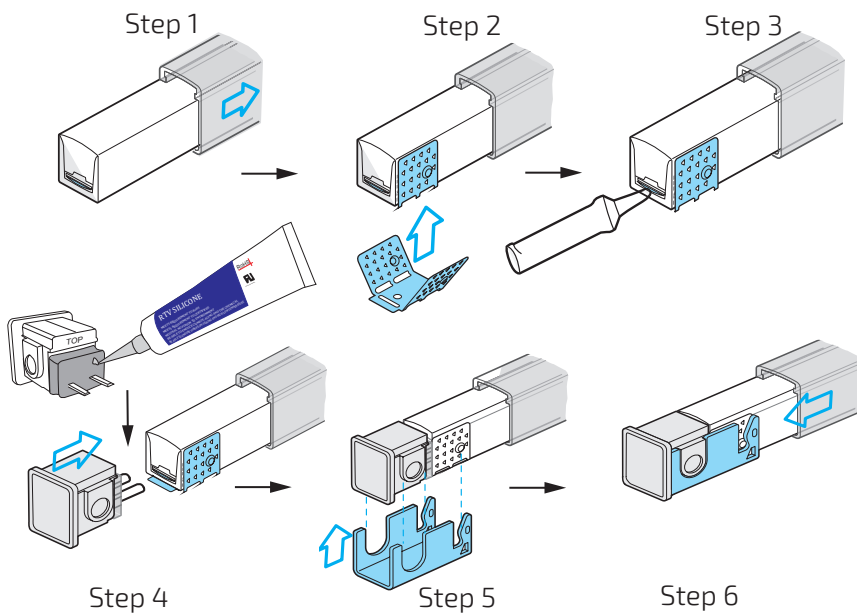
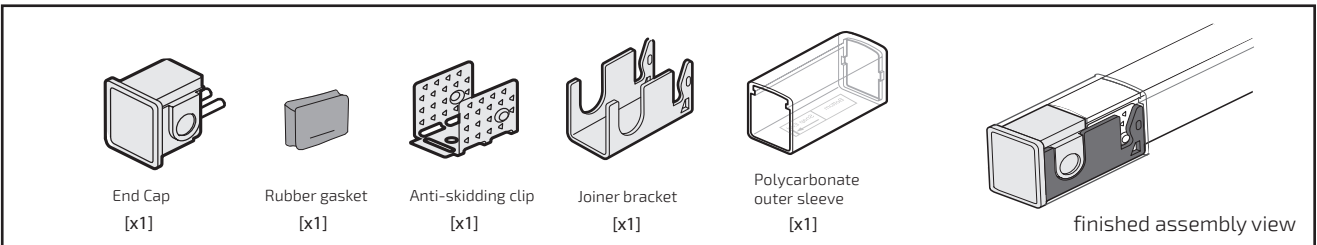

**Step 1**

Let neon flex goes through polycarbonate outer sleeve, printed instruction aligns with the 'Snap End' arrow points in the direction of end cap.

**Step 2**

Place the anti-skidding clip on the very end of the neon with the 2 tiny tabs that are pointing inwards still touching the end of material and crimp in place.

**Step 3**

Place the tip of the assistant tool against the outer side of the internal circuit board within the neon flex. Carefully push the tool into the neon flex (max. depth of 12.5mm) so that it creates a small cavity in the flexible material on the outer side of the circuit board.

**Step 4**

Insert rubber gasket into the pins and apply 100% clear silicone on the surface of it. Align end cap with the cut end part and carefully push its pins into the gaps.

**Step 5**

Gently yet firmly push the joiner bracket onto the end cap assembly. The two parts close together and eventually lock them into place.

**-Step 6**

Slide the polycarbonate outer sleeve and butts up to the flange of end cap.

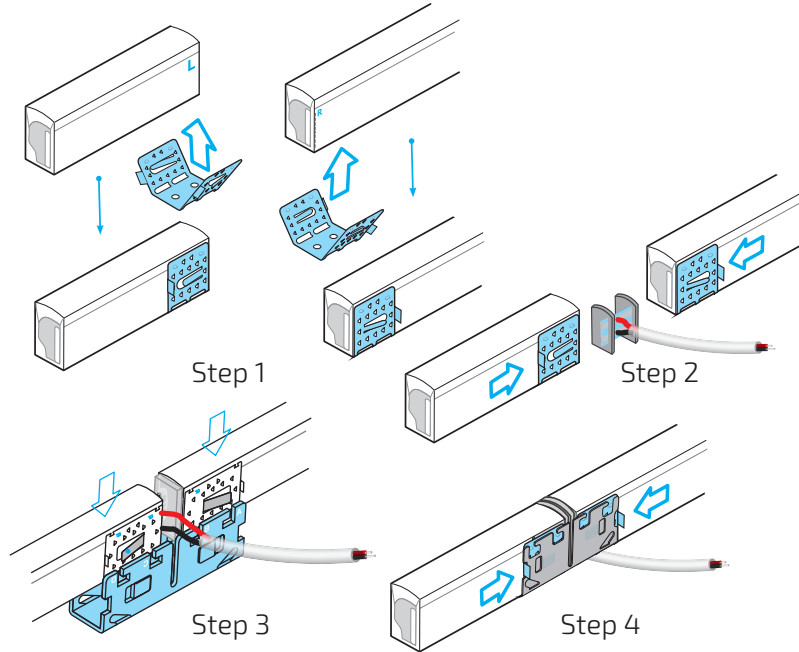
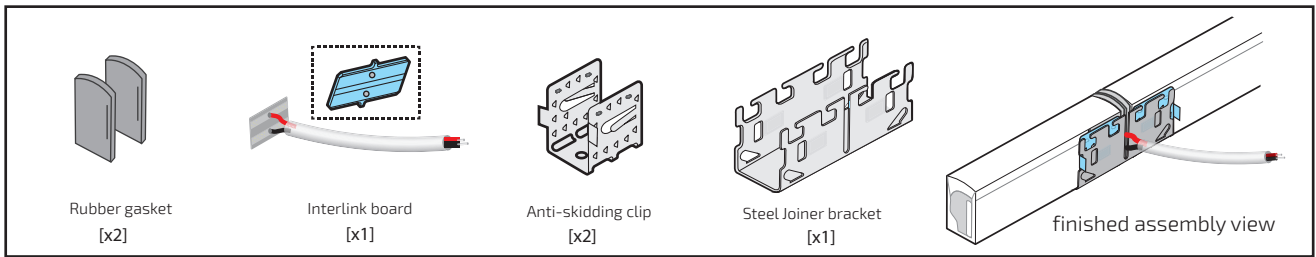

**Step 1**

Place anti-skidding clip onto both end of the neon flex, pay attention to its direction.

**Step 2**

Put rubber gasket on both side of interlink board, then insert interlink board into the gap created behind the FPCB.

**Step 3**

Align the anti-skidding clip with steel joiner bracket and press the neon flex downwards at the same time till bottom,

**Step 4**

Now push each neon flex in towards the center of joiner bracket, locking tabs on both grip clips click into place within their respective openings in the steel joiner bracket

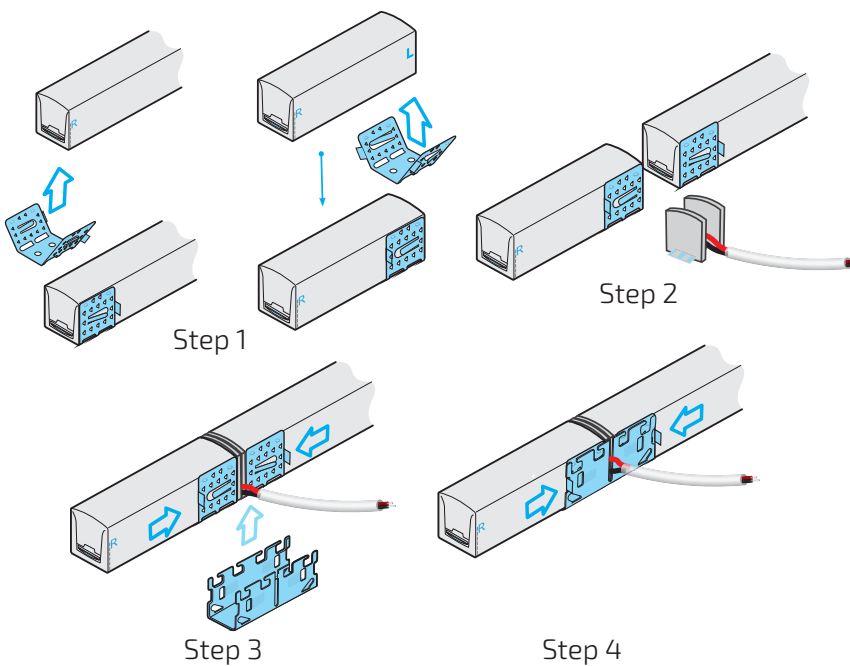
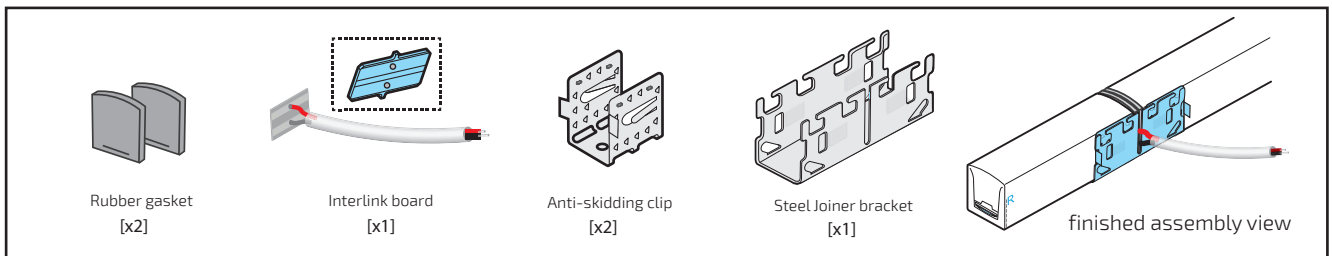

**Step 1**

Place anti-skidding clip onto both end of the neon flex, pay attention to its direction.

**Step 2**

Put rubber gasket on both side of interlink board, then insert interlink board into the gap created behind the FPCB.

**Step 3**

Align the anti-skidding clip with steel joiner bracket and press the neon flex downwards at the same time till bottom,

**Step 4**

Now push each neon flex in towards the center of joiner bracket, locking tabs on both grip clips click into place within their respective openings in the steel joiner bracket

## 7. Electrical Connections

LED neon flex is manufactured to order, meaning that the appropriate power feeds are moulded. There are two options available for all versions, these are bare end cables or plugs.

Bare end cables come with a standard length which can vary pending the manufacturing process, therefore it is recommended to ensure the feeder cable is long enough to reach the cable entry point of flex, where connections can be made.-

Plugs are designed for "plug-and-play" type installations, whereas the installer would ensure female sockets are available at each flex start location, with the male type connector then plugging into this female type socket. Female sockets are available as separate items.

Note that custom feed cable lengths are available upon special request.

LED neon flex is a high-powered product, which requires a detailed electrical design to ensure equal balancing of loads across drivers and power supplies. Reference can be made to the various data sheets for specific variants, that indicate the operating voltage and the wattage per metre. Technical support is on hand to assist with control and power design. Product operates at 24Vdc unless otherwise stated in specific data sheets or product labels. Care should be taken to ensure the operating voltage is constant (constant voltage). A maximum volt drop of 5% is allowed (for example at 24Vdc, the maximum voltage drop would be 1.2V meaning a delivered voltage of 22.8V to the fixture.

Providing with an extensive range of power supplies, LED Drivers, SPI pixel gateways and various DC-DC transformers which allow installers to overcome volt drop issues, as well as various control options such as stand-alone DMX interfaces to multi-universe video matrix type products. We also has an in-house design and engineering team that can deliver such systems, please contact support for more information.

Below is a guide which indicates the number of cores and the connections they relate to. Each manufactured length of flex will have a factory fitted label which indicates the correct cores to use, as well as the colour of each specific core and its associated connection. The below guide is in black and white for clarity, and reference should always be made to the label on the product itself as sometimes, the cable colours may vary pending manufacturing processes or for custom orders. If in doubt, or if the label is missing, contact support for assistance before connecting to power.

