

EVO-CO @ Air Purifier

DIMON
TECHNOLOGY

Air Purifier MULTI-FUNCTION Wall-mounted • Desktop

Product maintenance

Common failure	Possible cause	Troubleshooting
The unit is not working	Power cord is not plugged/ power has no electricity	Plug in the power supply/ Ensure the power supply is working
	Power switch is not on	Press "on/off" button
The purification effect is poor	End of service life	Change a filter
	Air inlet/outlet is blocked	Clean foreign parts of air inlet/outlet
The air volume is small	Wrong installation of the filter direction	Install filter in the right way
	The filter is too dirty	Change a filter
Abnormal noise exists		Please make sure all the package is removed.
		Please make sure the air inlet and outlet is not blocked by other stuff, and clean it if any. While turning on the negative ion function, "fizz" sound is normal.

If above corrective actions are not able to solve the problem, please contact sales and after-sales service assigned by our company. For safety, please do not disassemble the unit and maintain by yourself to avoid damage.

- Please do not plug or unplug the power by wet hands to avoid electric shock. Please unplug the power while moving the purifier.
- It is prohibited to use the device in moist area such as bathroom to avoid shock and accelerated aging of electrical system.
- The air purifier is not designed for filtering lampblack, it is prohibited to use the device in the area such as kitchen.
- High-pressure negative ion module is contained inside of the device, please do not disassemble or repair it if you are not an authorized technician. If needed, please contact any service network designated by Nuobio or return the device to Nuobio after-sales department.
- Please do not cover the air inlet and outlet, prevent the purification effect from being affected.
- It is prohibited to touch air inlet metal part and insert any foreign matter in air outlet, to avoid equipment malfunction.
- In case any damage on the appearance or interior, or any abnormal noise, peculiar smell, smog, please cut off the power in a safe way, and contact the seller promptly. Please do not disassemble the product.
- If the equipped power plug does not match with user socket, or damage occurs to the power wire, please contact the seller to change or allocate new parts. Please do not change the power wire to use adapter plug on your own. Please cut off the power by remove the plug if the product is not in use for a long time.
- Because of the difference of internal structure, all the front panel, filter or power wire change to this product should be offered by the manufacturer, please do not use other brand.
- This product is not able to eliminate carbon monoxide or radon, thus, in case any fire or chemical disaster, it can not be used as security appliance or replaced to duster or ventilate equipment.
- The microswitch decoration front panel only plays the function of connection, which can not be used as power switch. While replacing the filter or cleaning the interal parts, please turn off the power by On/Off button on the control panel then remove the plug.

PAGE 5

Warranty card

Dear customer,

Thank you for choosing our products. For your consumer rights and interests, please carefully read the warranty card and keep it properly. Items related to the product warranty are specified as follows:

1. We are responsible for free maintenance within one year since the date of purchase, in case any quality issue, you can maintain it at any our company's service network across the country by purchase invoice and this warranty card.
2. The following conditions are not in the scope of free repair service:
 - Damage by man-made causes (such as drop, crash, misplacement in the corrosive environment etc.);
 - Damage by irresistible reasons (such as earthquake, fire, flood and some other natural disasters);
 - Damage caused by maintenance technician who are not assigned by Nuobio;
 - Damage caused by violation of operating requirements noted in user manual;
 - Out of warranty or exchange period;
 - Unable to provide product warranty card.
3. Before returning the product, please ensure no damage of the appearance, complete package and accessories.

Please fill in the following information and keep it in a safe place

Product name : _____ Model : _____ Product code: _____

Username : _____ Telephone : _____

customer address : _____

Place for Purchase : _____ Date for Purchase : _____

Product warranty records:

NO.	Failure cause	Service man	Date	Maintenance results	Sign

Notes: The warranty card cannot be altered or reissued. Please keep it in a safe place.

PAGE 6

Air Purifier MULTI-FUNCTION Wall-mounted • Desktop

User Manual

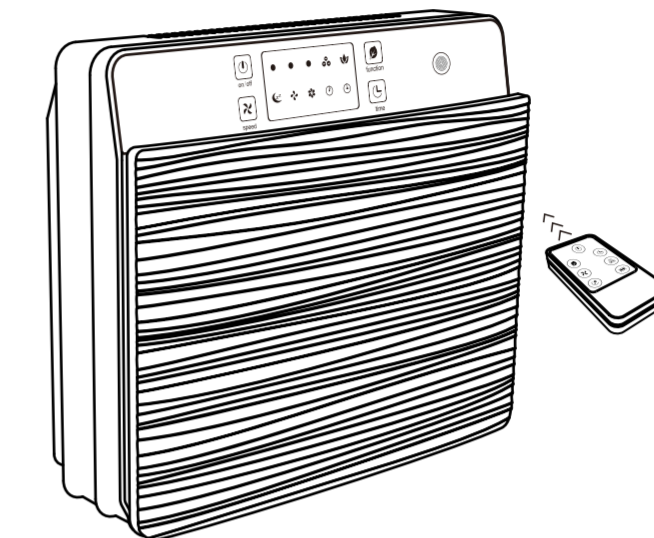

- Version : 202010
- Applicable to area of 10-15m²
- Multi-layer purification and filtration
- High efficiency composite HEPA filter
- Honeycomb activated carbon filter
- Infrared remote control
- Cold catalyst filter
- High-density negative ion
- UV sterilization
- High accuracy peculiar smell sensor
- Filter replacement warning
- Monitor the air quality, adjust purification mode automatically

- This product is researched and developed by professional design team on the basis of domestic environment and life style, which is suitable for all kinds of space. It plays the function of purifying indoor air and effectively removing harmful indoor gases (eg: formaldehyde), second-hand smoke, inhalable particulates(eg: PM2.5), killing bacteria and removing dust, dispelling peculiar smell etc.

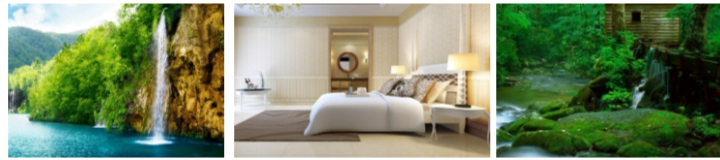

Use Environment

- This product is only applicable for houses or similar environment, which is prohibited for outdoor use.
- Do not use the device under the environment of high temperature, high humidity, excessive dust, corrosive, flammable and combustible gas (such as kitchen and bathroom).
- Do not use the device around heating equipments (such as oven, fan heater or other heating devices) or under direct sunshine.
- Do not use the device while the temperature varies seriously; do not use aromatherapy or other spray before or when the device is on.
- While working, the device should be placed on steady and dry horizontal plane without any incline.
- While working, please ensure the inlet and outlet is 30cm far away from other stuff.
- For the power parameter of this device, please refer to the electric table in the last page of this manual.

While designing and manufacturing, special requirement of young, weak and handicapped is not considered, therefore, this device is not applicable to this group unless with the help of adult healthy people, for the safety.

Specification

Rated Voltage	AC110-240V	Rated Power	8.5W or 13W
Rated Frequency	50/60Hz	Noise Index	53dB
CADR	62/92.1m ³ /h	Net Weight	2.5kg
Application Area	≤15m ²	Size	334*129*295mm

All the specification of above table is measured data, due to different service environment, there may be some changes, please note. If the product is technically updated, please be subject to the new instructions, no further notification will be published.

PAGE 1

Operation method

- **Starting up:** After connecting with the power, slightly touch the "On/off" to start up the purifier, a second touch of "On/off" button turns off the device.
- **Air speed:** Three air speed gears of "sleep mode, standard speed, fast speed" are designed for this device. The machine runs at "standard speed" by default after the machine is turned on. After the purifier is turned to "sleep mode" for 10 seconds, all the indicators except the "sleep mode" indicator are off. When any button of the machine is manually adjusted, the indicator returns to the normal display state.
- **Timing:** Two options of "1 hour, 3 hours", slightly touch "timing" button for successive choices.
- **Sterilization:** After starting up, the user could slight touch "function" button to turn on and turn off the UV lamp, which can sterilize the indoor air.
- **Negative ion:** It is default to turn on "negative ion" function after starting up, which is automatically off after device shutdown. While the device is on, the negative ion module continuously emits 20mins negative ion then stops for 5 mins to repeat this action.
- **Automatic air quality detection:** The device is equipped with built-in high sensitive peculiar smell sensor. The first 2 minutes after the machine is turned on is the sensor warm-up process. At this time, the air quality indicator is not bright. After 2 minutes of warm-up, the air quality indicator can automatically detect the air quality according to the sensor detection signal.
- **Automatic and manual speed control:** The default speed is the automatic speed control mode after the machine is turned on. In this mode, the wind speed will be automatically adjusted according to the air quality level. When manually adjusting the wind speed, the machine enters the manual mode. In this mode, the wind speed will not automatically follow the change of air quality, and can only be adjusted manually. If it is necessary to restore the automatic speed regulation, you need to restart the machine and then restart it.
- **Filter replacement warning:** When accumulated operational time reaches 1500hours, the three indicator lights of air quality flash simultaneously, it reminds the user to replace the filter by alarm sound of "di di di". After the replacement, push "timing" and "air speed" buttons for 5 seconds to reset and eliminate the alarm.
- **Remote control:** The device is equipped with infrared remote controller, effective distance is 4-5 meters. While using, it is suggested to direct to the IR receiving window on the right of the control panel to achieve a better function.

Preparations before use

Please remove the package, protection film on the product and plastic bag of the filter before usage.

Method of disassembling

Please place the device on steady and dry horizontal plane and ensure 30cm far away from other stuff. Before plug into the power, please make sure the socket and power wire satisfy the requirement of this product.

PAGE 2

Product Breakdown Drawing

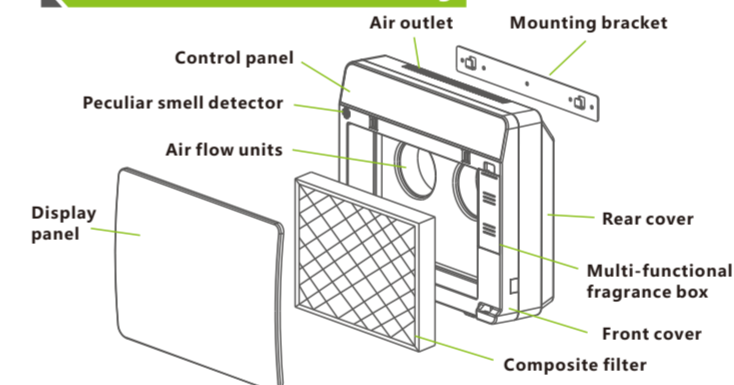

Multi-functional fragrance box

One large and multi-functional fragrance box is originally designed to this product, the user is able to add different fragrance into the box according to its own interest and different environment condition, for instance, bottled perfume, aglawood, pasty fluid fragrance, fragrance bead, dried flower and etc, which immediatly fills the whole room with healthy and fresh fascinating smell.

Product operation guide

Please make sure the power is shut down and the plug is pulled out before disassembling the product. Tip: while disassembling, the product could be laid again the wall or other fixed object to enhance the stability.



Disassemble the front panel / Disassemble the filter

Hold the top by left hand, hold the top edge of the front panel by right hand, pull the panel out to a 45-degree angle, then lift up the panel. / Pull and hold the two braces on both sides of the five-in-one filter by both hands, then pull it slightly to disassemble it.

PAGE 3

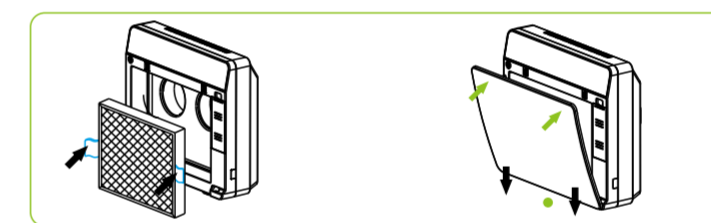

Assemble the filter/ Assemble the front panel

Align the filter to the slot, the side with braces outward, then push into the unit slightly. / Insert the bottom buckle to the holes in the front cover, then assemble the front panel into the cover slightly.

- The lifetime of the filter differs based on indoor environment, usage times and usage location.
- To improve the efficiency, please purchase the filter suggested by Nuobio.
- Please make sure the power is cut off before replacing new filter.
- Primary anti-microbio filter should be cleaned by soft brush every half month to clear away the large pollutant, like hairs.

Warning

Do not flush by water or soak any filter to be used on this product.

	Filteration system	Function
Layer one	primary anti-microbio filter	Filter large particle or hair
Layer two	High efficiency HEPA filter	Filter PM2.5, source of allergy, powder, bacteria, virus and mycete
Layer three	Honeycomb activated carbon filter	Eliminate peculiar smell, absorb harmful gas
Layer four	Cold catalyst filter	Efficiently resolve formaldehyde, benzene, ammonia gas, TVOC, sulfuretted hydrogen or other harmful gas
Layer five	UV sterilization	Efficiently kill all kinds of bacteria for disinfection
Layer six	Negative ion	Eliminate dust, fresh the air, remove indoor static electricity for sterilization

PAGE 4