

NOTES

GENERAL NOTES.

1. FIRST ANGLE PROJECTION.



2. DIMENSIONS SHOWN IN BRACKETS THUS (25) ARE REF. DIMENSIONS ONLY.

3. REMOVE ALL BURRS AND SHARP EDGES.

4. DO NOT SCALE IF IN DOUBT ASK.

5. WELDING SYMBOLS ARE TO AWS D1.1

6. ALL STANDARDS AND SPECIFICATIONS ARE TO BE TO THE LATEST REVISIONS.

7. HOT DIP GALVANIZED TO ASTM_A123



PAN/TILT/ZOOM CAMERA
SIZE: 210X366X498mm
WEIGHT: 14kg

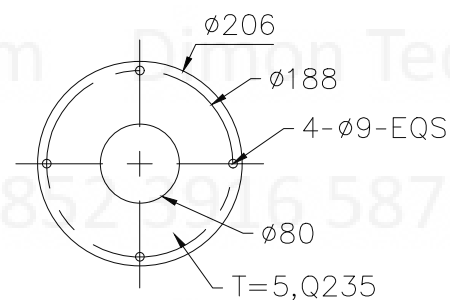

DETAIL OF TOP FLANGE

WASHER PUMP
SIZE: 217X272X257
WEIGHT: 8.8kg

WASHER BRACKET

$\phi 89 \times 4.0_{-Q345}$

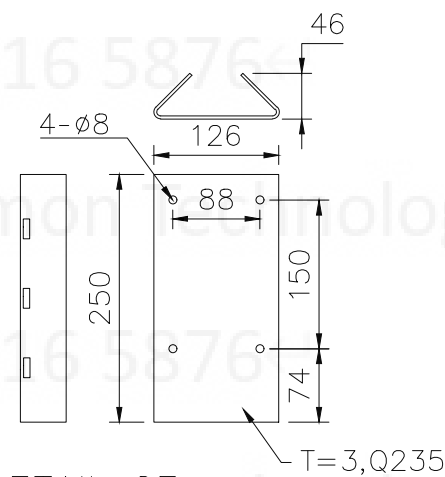

DETAIL OF WASHER BRACKET

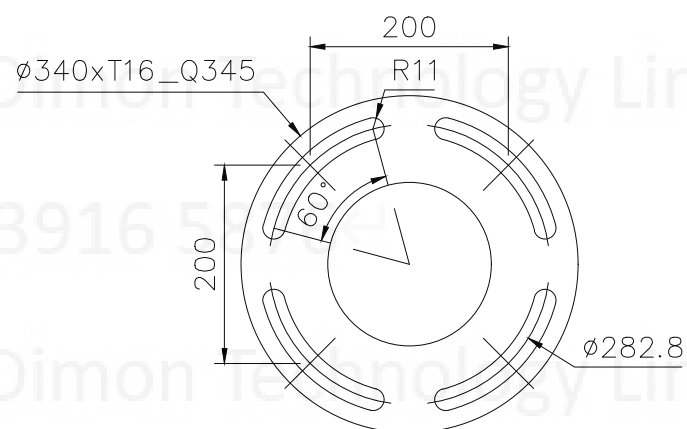

DETAIL OF BASE FLANGE

DIMON
Technology

DIMON Technology Ltd.

Tel: 00852-3916 5876

Fax: 00852-21203398

Http: //www.dimontechnology.com

E-mail: gary@dimontechnology.com

CLIENT

TITLE

HX Pole -CCTV Hinged Columns-5M

			DRAWN		MATERIAL		MANUFACTURING ORDER
			ENGR		THK(mm)		
			CHECKED		WT(kg)		
A			SPECIFICATIONS		SCALE		
REV ID	DATE	REVISION DESCRIPTION					

Email: gary@dimontechnology.com Dimon Technology Limited

www.dimontechnology.com T: +852 3916 5876

Email: gary@dimontechnology.com Dimon Technology Limited

www.dimontechnology.com T: +852 3916 5876

Email: gary@dimontechnology.com Dimon Technology Limited

www.dimontechnology.com T: +852 3916 5876

Email: gary@dimontechnology.com Dimon Technology Limited

www.dimontechnology.com T: +852 3916 5876

Email: gary@dimontechnology.com Dimon Technology Limited

www.dimontechnology.com T: +852 3916 5876

Email: gary@dimontechnology.com Dimon Technology Limited

www.dimontechnology.com T: +852 3916 5876

Email: gary@dimontechnology.com Dimon Technology Limited

www.dimontechnology.com T: +852 3916 5876

Email: gary@dimontechnology.com Dimon Technology Limited

www.dimontechnology.com T: +852 3916 5876

Email: gary@dimontechnology.com Dimon Technology Limited

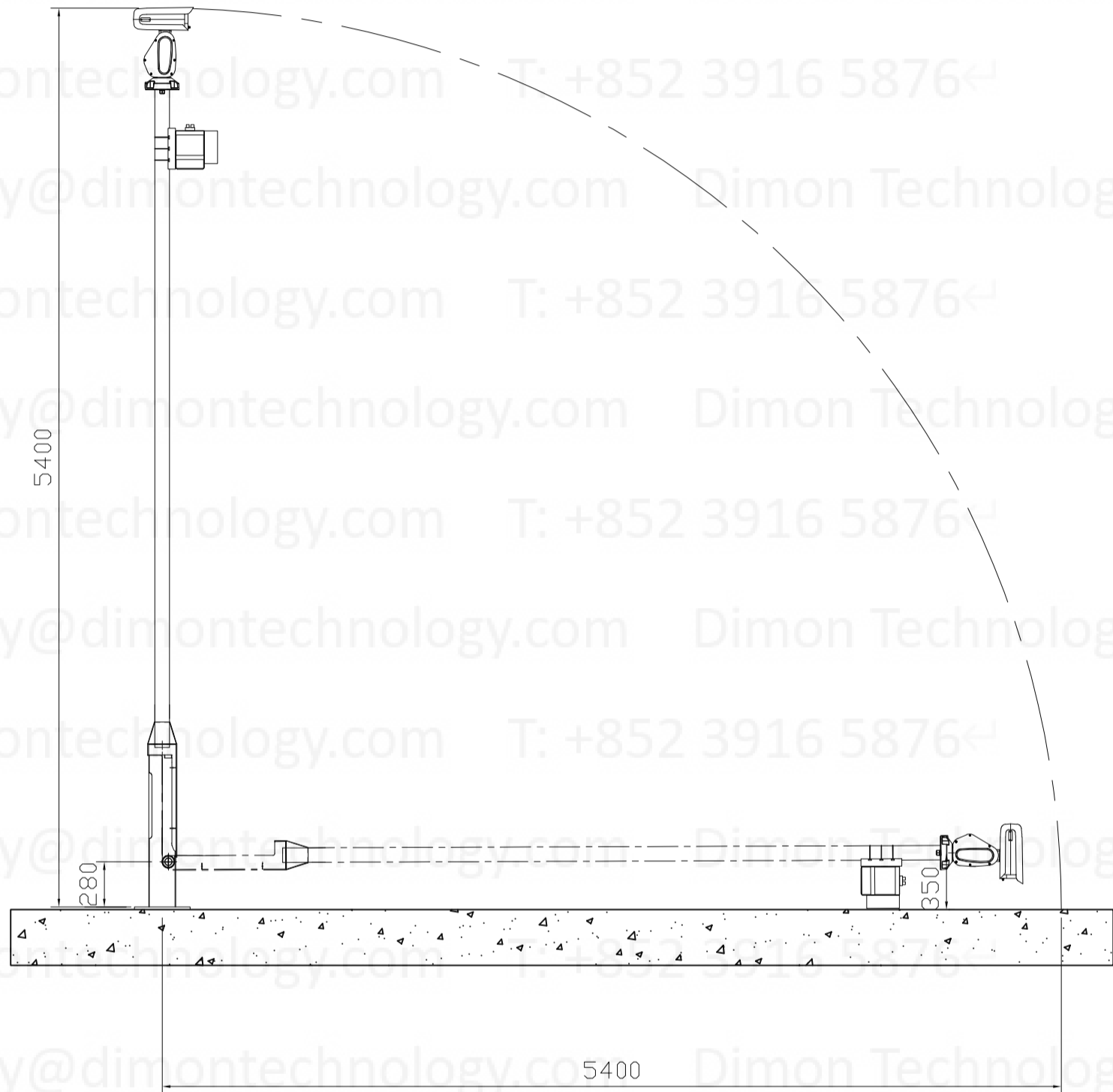

DIMON

Technology

DIMON Technology Ltd.

Tel: 00852-3916 5876

Fax: 00852-21203398

Http://www.dimontechnology.com

E-mail: gary@dimontechnology.com

CLIENT

TITLE

HX Pole -CCTV Hinged Columns-5M

			DRAWN		MATERIAL		MANUFACTURING ORDER
			ENGR		THK(mm)		
			CHECKED		WT(kg)		
A			SPECIFICATIONS		SCALE		
REV ID	DATE	REVISION DESCRIPTION					

Email: gary@dimontechnology.com Dimon Technology Limited

www.dimontechnology.com T: +852 3916 5876

Email: gary@dimontechnology.com Dimon Technology Limited

www.dimontechnology.com T: +852 3916 5876

Email: gary@dimontechnology.com Dimon Technology Limited

www.dimontechnology.com T: +852 3916 5876

Email: gary@dimontechnology.com Dimon Technology Limited

www.dimontechnology.com T: +852 3916 5876

Email: gary@dimontechnology.com Dimon Technology Limited

www.dimontechnology.com T: +852 3916 5876

Email: gary@dimontechnology.com Dimon Technology Limited

www.dimontechnology.com T: +852 3916 5876

Email: gary@dimontechnology.com Dimon Technology Limited

www.dimontechnology.com T: +852 3916 5876

Email: gary@dimontechnology.com Dimon Technology Limited

www.dimontechnology.com T: +852 3916 5876

Email: gary@dimontechnology.com Dimon Technology Limited

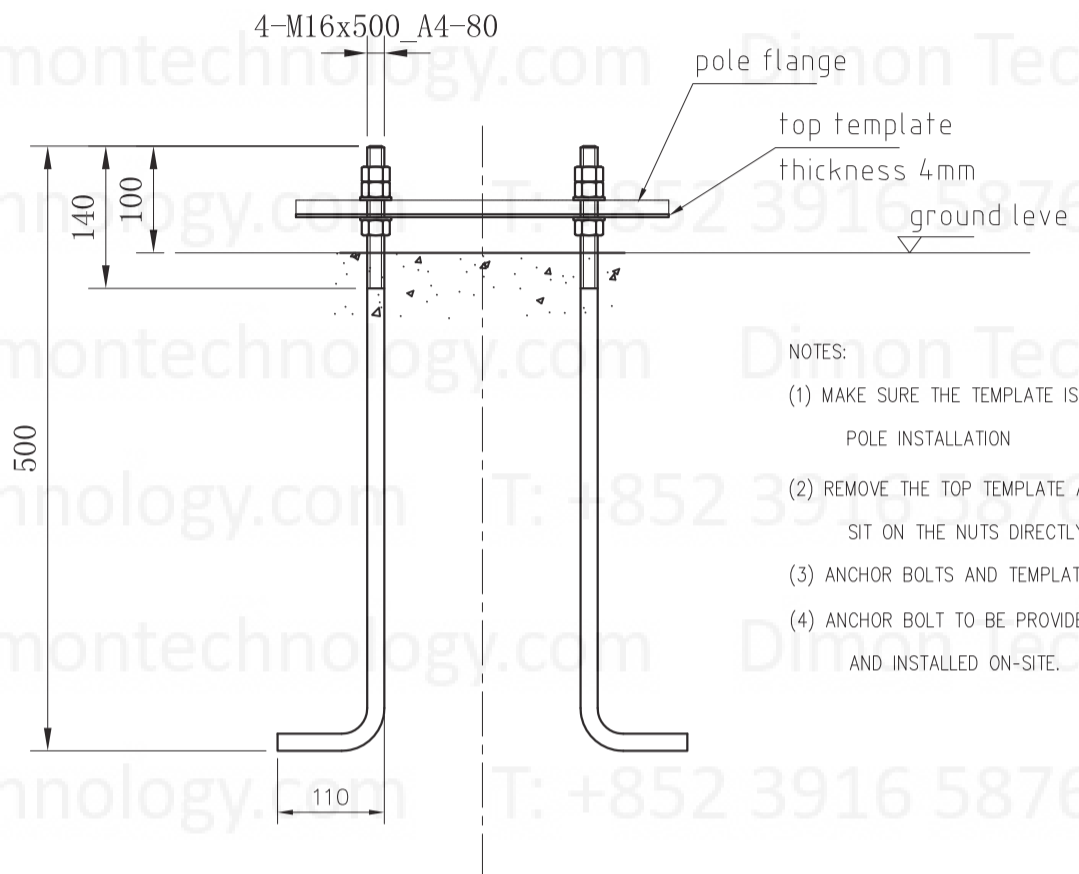

- NOTES:
- (1) MAKE SURE THE TEMPLATE IS HORIZONTAL BEFORE POLE INSTALLATION
 - (2) REMOVE THE TOP TEMPLATE AND LET THE BASEPLATE SIT ON THE NUTS DIRECTLY WHILE INSTALLING POLE
 - (3) ANCHOR BOLTS AND TEMPLATE ARE GALVANIZED
 - (4) ANCHOR BOLT TO BE PROVIDED UNASSEMBLED AND INSTALLED ON-SITE.

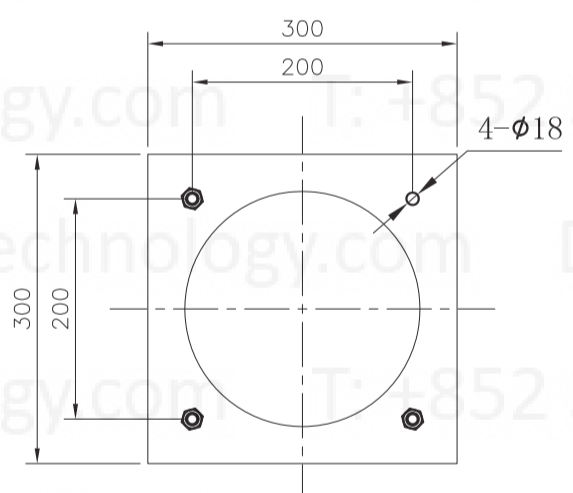

detail of template

DIMON
Technology

DIMON Technology Ltd.
Tel: 00852-3916 5876
Fax: 00852-21203398
Http://www.dimontechnology.com
E-mail: gary@dimontechnology.com

CLIENT			
TITLE		HX Pole -CCTV Hinged Columns-5M	
QD210273-T050RLS-FB	DRAWN	MATERIAL	MANUFACTURING ORDER
	ENGR	THK(mm)	
	CHECKED	WT(kg)	
REV ID	DATE	REVISION DESCRIPTION	SPECIFICATIONS
			SCALE