

Multi-connection Installation

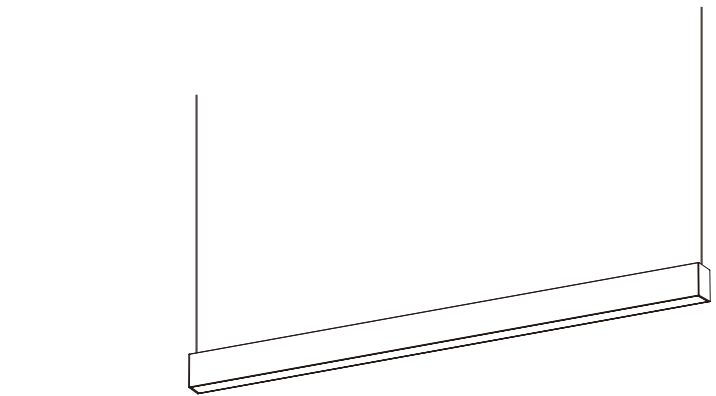

Reflector Type

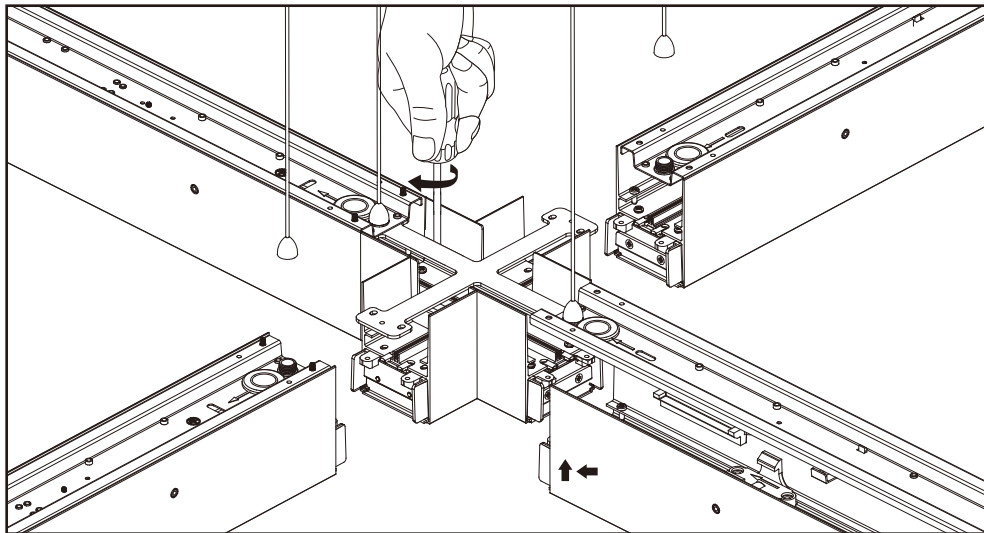
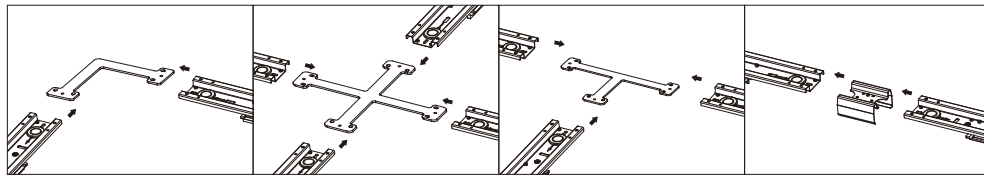
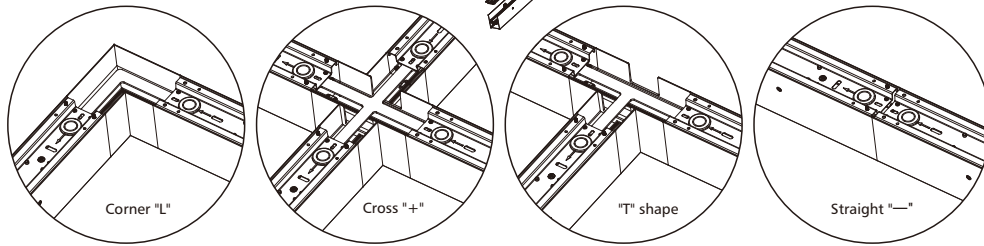
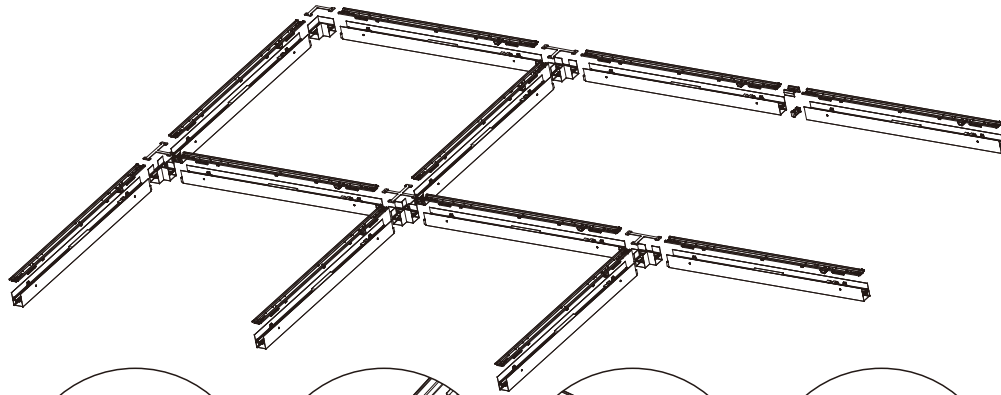
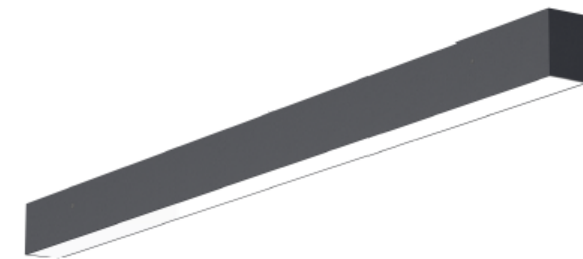

Opal Diffuser Type



Continuous Joint

## Safety Instructions

To ensure correct function and safety, please read and follow all instructions carefully before using the product:

1. Turn off power before installation or before doing any maintenance work.
2. Do not install any luminaire near the heat source.
3. Do not exceed the nominal supply voltage or amperage ratings.
4. Dimmable version could be compatible with a wide range of recommended DALI/0-10V dimmers.
5. All wiring and installation of the light fitting must adhere to local and national wiring rules.
6. Take care not to pull any electrical wires during unpacking as this may damage the connection.
7. Lay out all the components on a smooth surface and make sure there are no components missing before assembling.
8. To avoid injury or damage to the fitting, please ensure that power leads and screws are secure before connecting the power.
9. Please keep instructions for future reference.

## Installation Procedure

### WARNING

1. Switch off before installation / maintenance.
2. Switch on only after complete installation and examination of the circuit.
3. Professional electrician for installation and maintenance only.

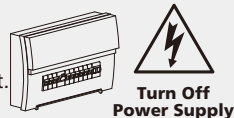

Turn Off power supply before starting any installation. Read instructions & check you have all the tools & accessories to complete the installation correctly. The light source contained in this luminaire shall only be replaced by the manufacturer or his service agent or a similar qualified person.

## LiFePO4 battery lifetime

1	15-25°C battery at the condition of open circuit	24 months
2	15-25°C battery under normal operation condition (charge and discharge once a month at least)	48 months
3	To achieve the best using effect, the battery should be charged and discharged every three months	After 6 months from suppliers

(Notice: No explosion, fire, or smoke during charge or discharge period.)

Precautions for storage, transportation, and usage

1. The battery should be stored under 30°C, ambient temperature for storage should not exceed 35°C, or the self-discharge of the battery will increase and the electrical performance will be influenced.
  2. The battery must be insulated during assembly into the final product to prevent the battery from being short-circuited. The handling and transportation of the battery must be handled gently to prevent the battery from being damaged by external force.
  3. Never charge battery with a charger not specifically compatible with it! ONLY use a charger which can apply the "constant current / constant voltage" (cc/cv) charge technique with LiFe voltage settings.
- Notice: The supplier shall bear the responsibility for the loss of the product unqualified performance, shall not bear any responsibility for the loss which is caused by improper use, storage or transportation.

## Surface mounted installation

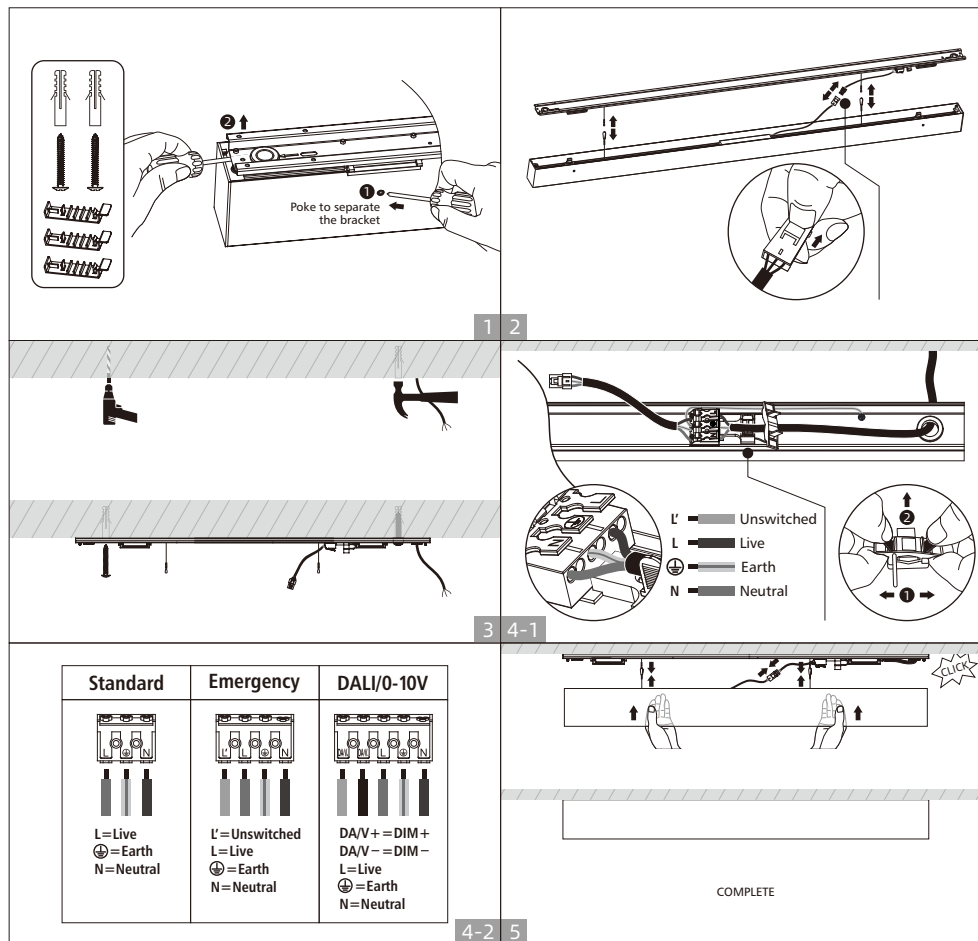

## Suspended installation (Without round ceiling plate)

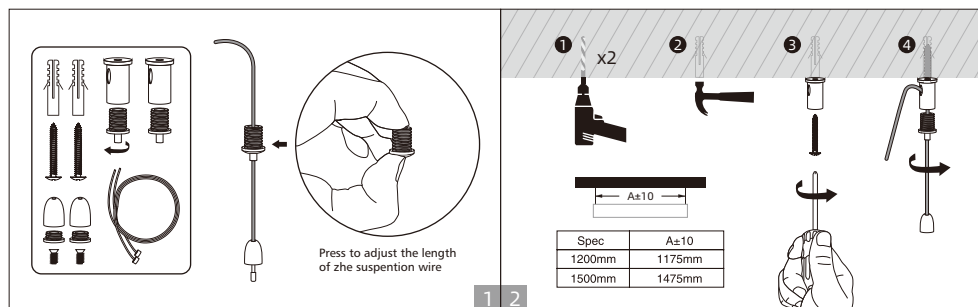

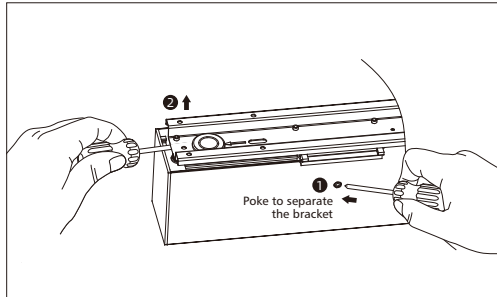

3 4

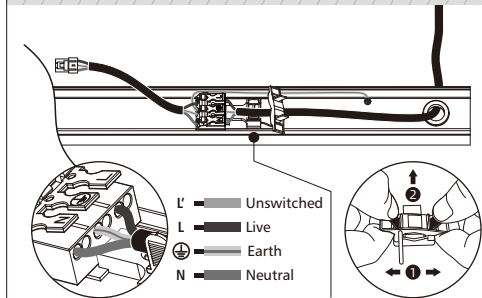
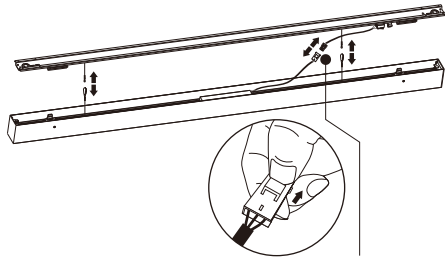

5

Standard	Emergency	DALI/0-10V
L = Live ⊕ = Earth N = Neutral	L' = Unswitched L = Live ⊕ = Earth N = Neutral	DA/V+ = DIM+ DA/V- = DIM- L = Live ⊕ = Earth N = Neutral

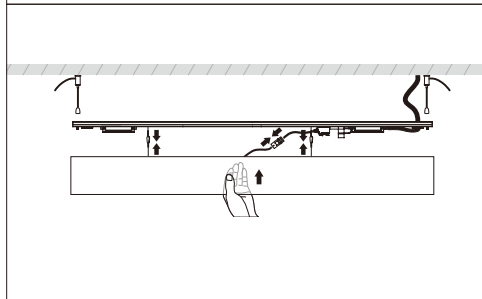

6 7

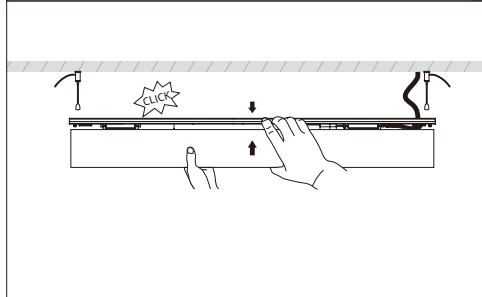
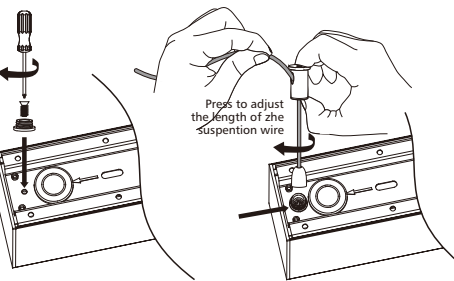

8 9

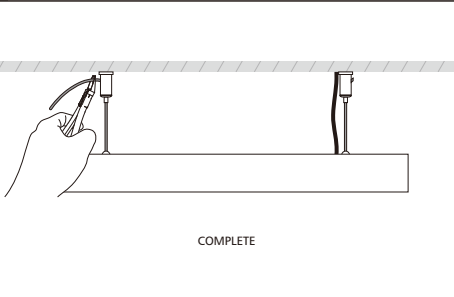

3

## Suspended installation (With round ceiling plate)

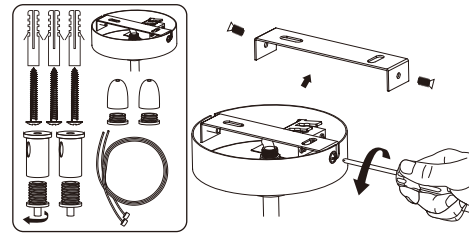

1 2

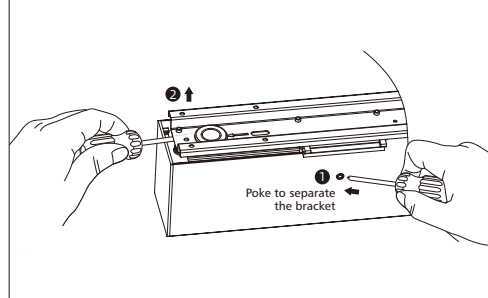
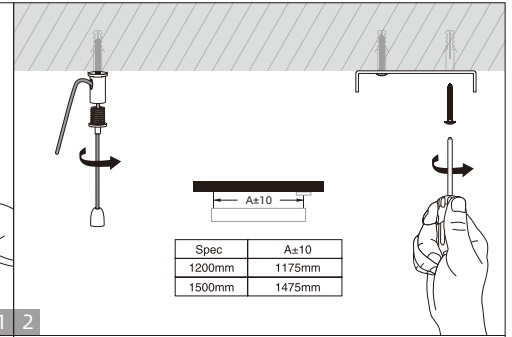

3 4

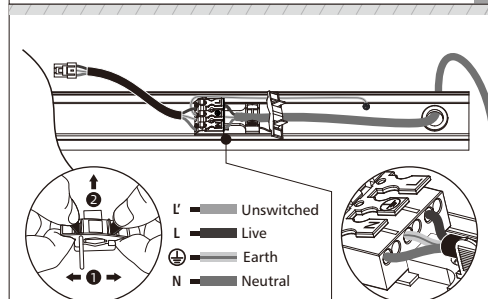
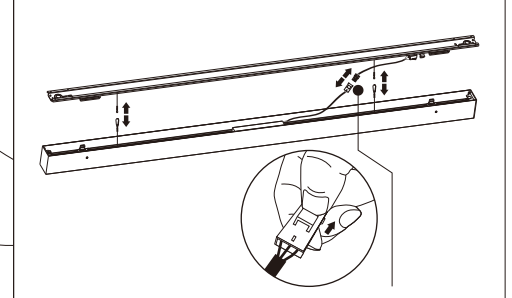

5

Standard	Emergency	DALI/0-10V
L = Live ⊕ = Earth N = Neutral	L' = Unswitched L = Live ⊕ = Earth N = Neutral	DA/V+ = DIM+ DA/V- = DIM- L = Live ⊕ = Earth N = Neutral

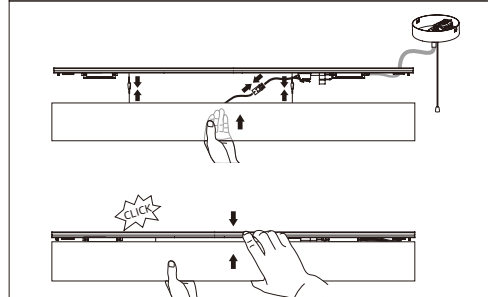

6 7

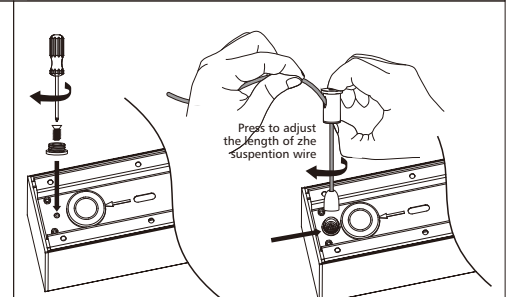

4

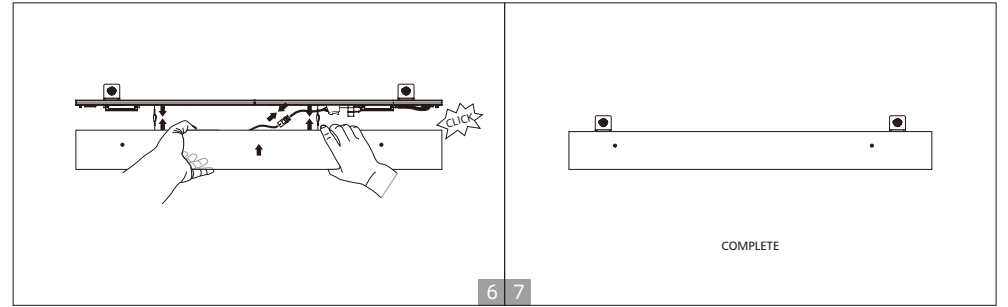
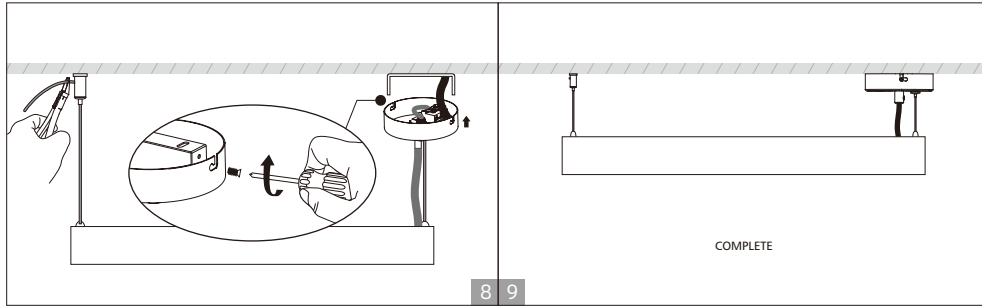

### Wall mounted installation

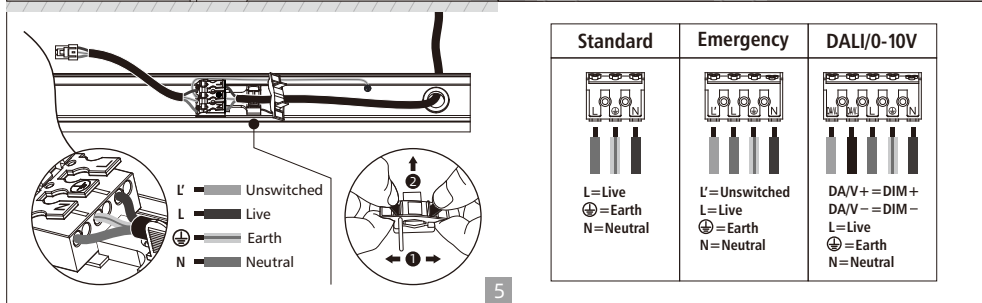
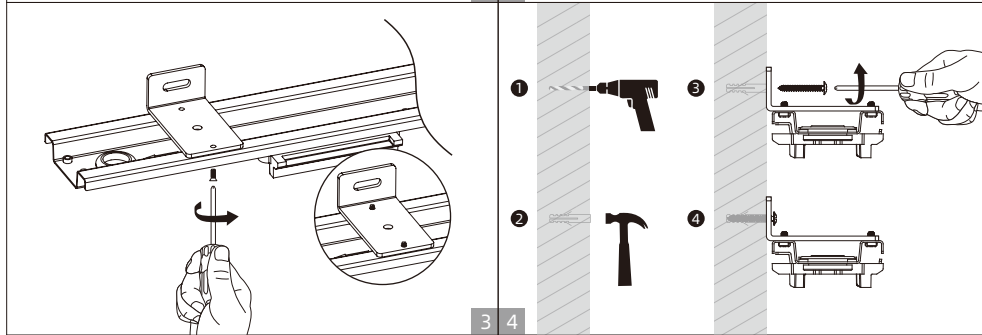
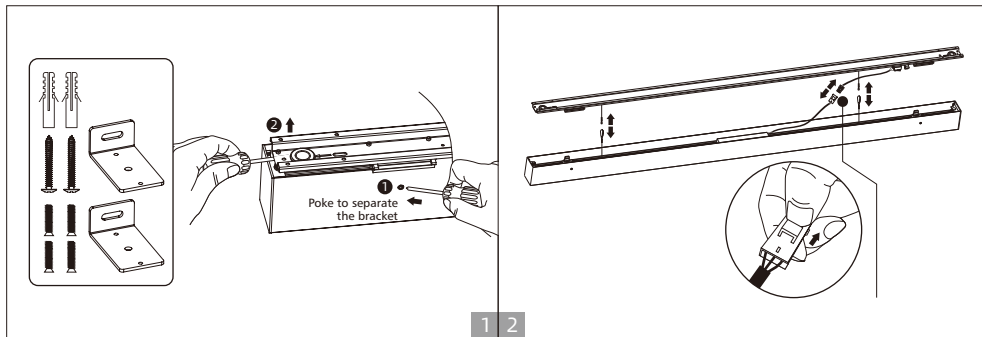

### Recessed installation

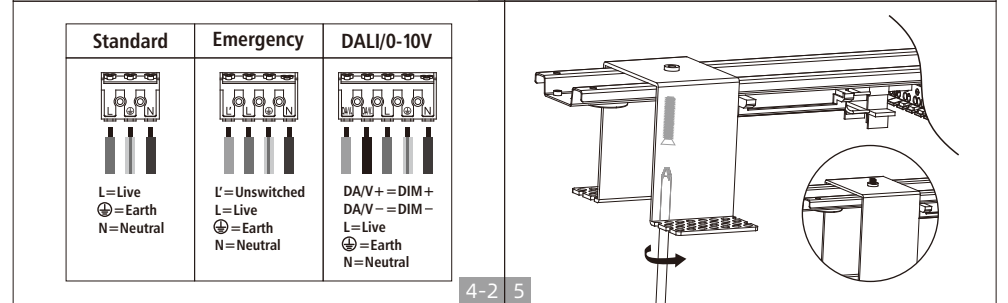
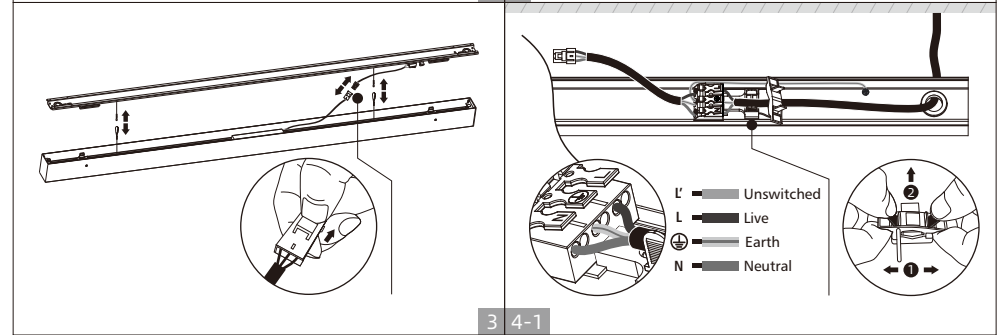
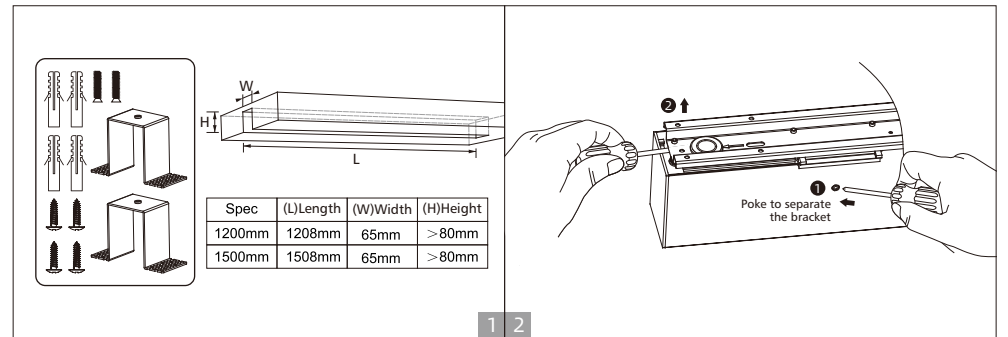

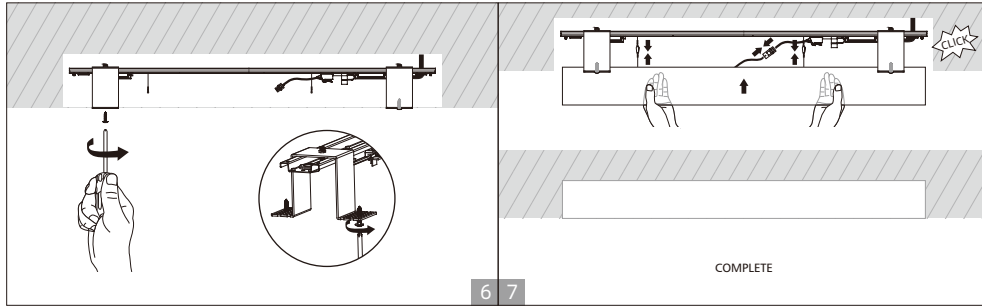

### Track installation

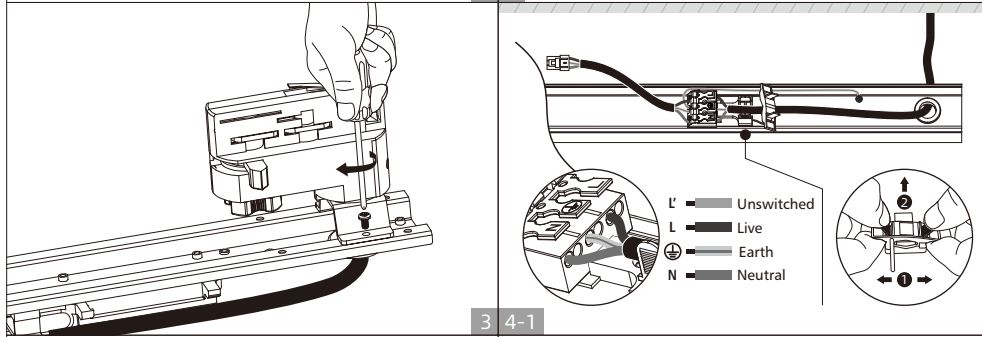
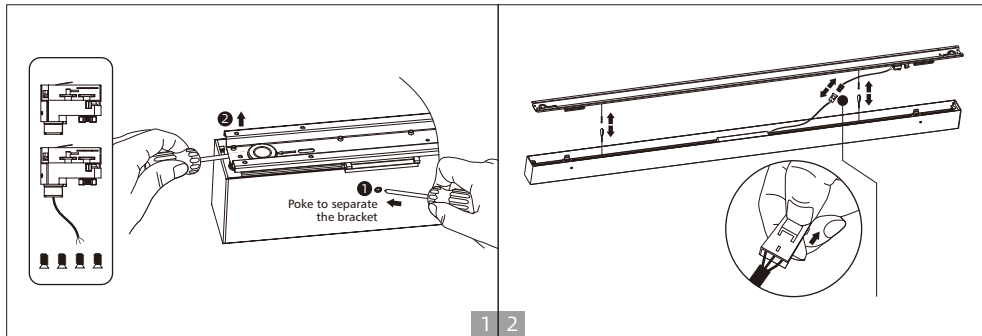

Standard	DALI/0-10V
L = Live ⊕ = Earth N = Neutral	DA/V+ = DIM+ DA/V- = DIM- L = Live ⊕ = Earth N = Neutral

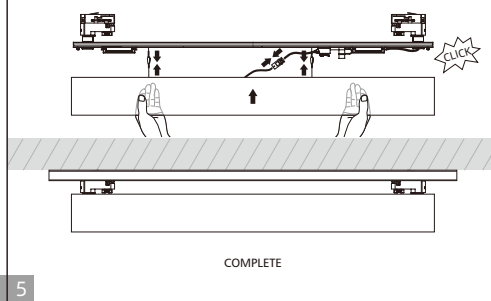

### Surface mounted installation

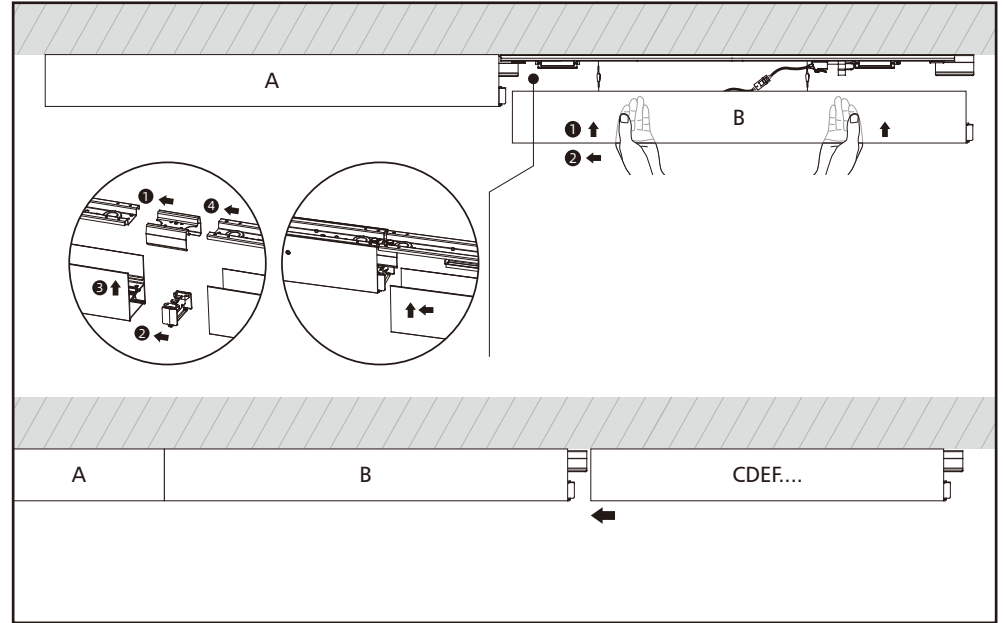

### Wall mounted installation

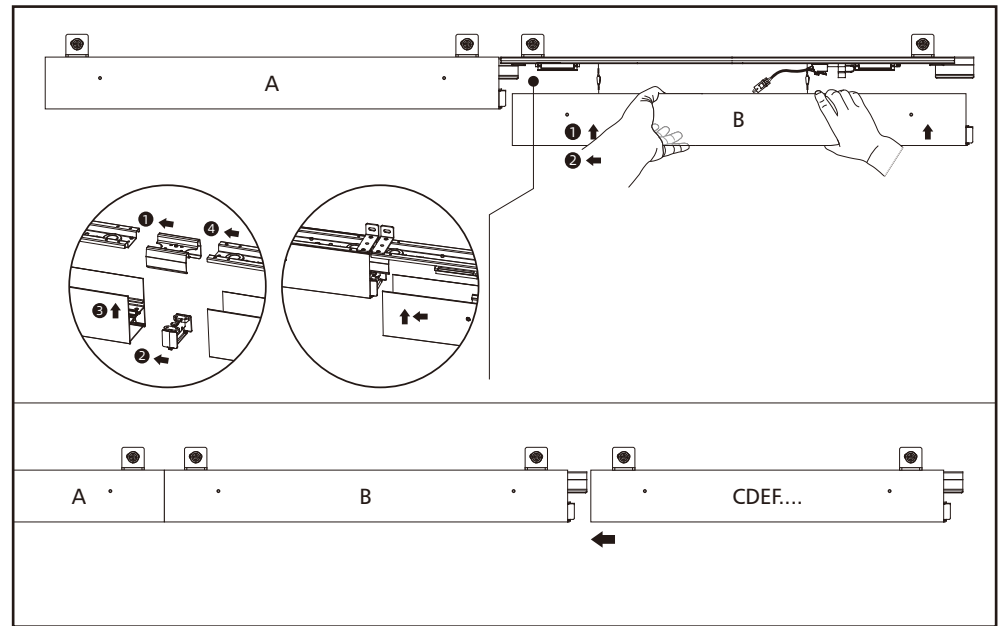

### Recessed installation

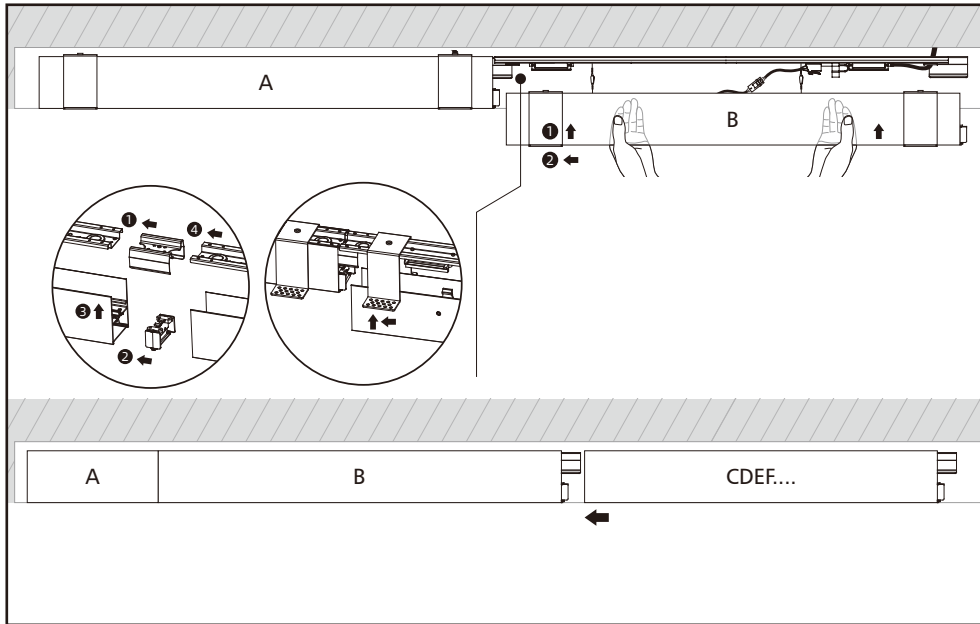

### Suspended installation

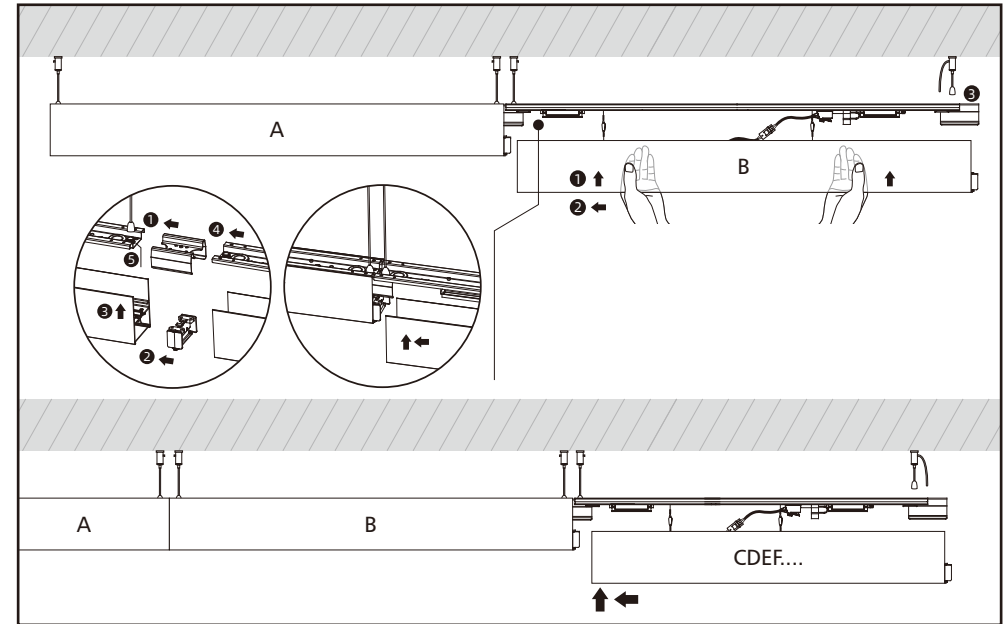

### Track installation

