









ARUA-S

Dia 320mm Max 24W IP65



- Housing finished : Die-cast aluminium base with vandal resistant Polycarbonatel diffuser which is self-extinguishing fire properties.
- And, It is able to be controlled by Dual Mode (Daylight and Microwave motion) Occupancy Sensor control , 1-10V and DALI.

Technical Data

Luminaire Type-安裝方式-Tipo de luminaria	Ceiling or Wall Mount Type吸頂或吸壁安裝Tipo mount en el techo
Dimension-尺寸-Dimensión	Dia 320 x H:100mm
Power Consumption Max-燈具功率Consumo de energía Max	12W 15W 20W 22W 24W
Input Voltage-輸入電壓-Voltaje de entrada	AC220V-240V 50/60Hz
LED Driver Type LED驅動款式 Tipo de controlador LED	Integrated-type LED Driver--Refer to LED driver specification 請參閱LED驅動器規格 Consulte la especificación de controlador de LED 1. ON/OFF Switch 2. 1-10V Dimming Driver 3. Dali Dimming Driver 4. Stand-alone Dual Mode (Daylight and Microwave motion) Occupancy Sensor control with belwo Setting: • Hold-time: 5s/30s/1min/5min/10min/20min/30min • Stand-by period: 0s/10s/1min/5min/10min/30min/1H/ non limitation • Stand-by dimming level 10%/20%/30%/50% (0-10V dimming control) • Daylight threshold 2~50Lux, disable • Detection range: Max. (Diameter x H): 12m x 6m • Detection area distance setting: 10%/50%/75%/100% • Detection angle: 30° ~150° 5. ZIGBEE Wireless LED Driver 6. Emergency Backup >2 hours or >3 hours @ < 12charger hours應急電池/Copia de seguridad de emergencia
LED Driver Features驅動特性 Funciones del controlador de LED	POWER FACTOR : PF>0.90 or PF>0.95 TOTAL HARMONIC DISTORTION: THD< 20% Refer to LED driver specification 請參閱LED驅動器規格Consulte la especificación de controlador de LED
Control Protocol-控制協議 Protocolo de Control	1-10V / Dali / Zigbee / Stand-alone Dual Mode (Daylight and Microwave motion) Occupancy Sensor
Beam Angle光束角ángulo de haz	120°
Light Source Brand-光源品牌-Fuente de luz de marca	OSRAM SMD LED
"Lumen Maintenance LM-80 Reported by TM-21"@25 °C	L70(10k) > 60,500 hrs
LED Life-LED壽命-La vida del LED	>60,000 hours
Color Temperature -色溫Temperatura del color	2700K / 3000K / 4000K / 5000K / 6000K
Color Rendering Index-顯色指數 Índice de reproducción cromática	> 80 > 90
MacAdam Ellipses Binning 麥克亞當橢圓分級 Mac Adam binning elipse	Standard Deviation Colour Matching < 3 SCDM 標準偏差配色 < 3 SCDM Coincidencia de color estándar Desviación
Luminaire Efficacy燈具效率 La eficacia de la luminaria	• 100Lm/w(2700K), 110 Lm/w(3000K), 120 Lm/w(4000K), • 120Lm/w(5000K), 120 Lm/w(6500K),
LED Source Luminous EfficacyLED光源光效 Fuente luminosa LED Eficacia	• 130Lm/w(2700K), 140 Lm/w(3000K), 150 Lm/w(4000K), • 150Lm/w(5000K), 150 Lm/w(6500K),
Housing materials-外殼材料 Materiales de la carcasa	Die-cast aluminium and Anti UV Polycarbonate Prisms diffuser 壓鑄鋁和抗紫外線PC稜鏡擴散器 Difuser de Prismas de Aluminio inyectado y Policarbonato Anti UV
Housing Color外殼顏色color de la carcasa	Powder Coating Matte white RAL 9003 粉末塗料啞光白 RAL 9003 Revestimiento en polvo Blanco mate RAL 9003
Ingress Protection-防護等級 Protección de ingreso	IP65
Mech impact protection 機械衝擊保護 Protección contra impactos mecánicos	IK10
Operating Temperature Range / 工作溫度範圍 Rango de temperatura de funcion amiento	-30 °C / +50 °C
Operating Humidity -工作濕度 Humedad de funcionamiento	0~90%, non-condensing-不結霜 sin condensación
Comply Testing Standard 符合測試標準 Cumplir el estándar de prueba	ED Luminaires: IEC/ EN 60598-1 / EN 60598-2-1 / EN 62031 / EN 62493 / IEC/EN 62471 / IEC 60598-2-22 / IEC 62031 / EN 55015 / EN 61000-3-2 / EN 61000-3-3 / EN 61547 / IEC 62262 / IEC 60529 / IEC TR62778 Luminaries Performance : IEC 62722-1 / IEC 62722-2-1 FSD regulation PPA 104A (4th Rev). RoHS
Certification-認證-Certificación	        

Project	Fixture#	Date
		Firm

Ordering Information

Choose the option that suits your need and write its corresponding code on the appropriate line to form the product code.

Example product code: [ARUA-20W](#)

ARUA- - - _____
Power Consumption

Power Consumption	
Code	Description
12W	12W
15W	15W
20W	20W
22W	22W
24W	24W

Occupancy Sensor Detection Pattern

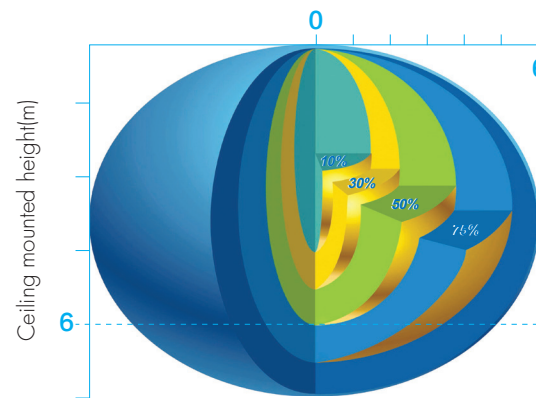

Ceiling mounted detection pattern (m)

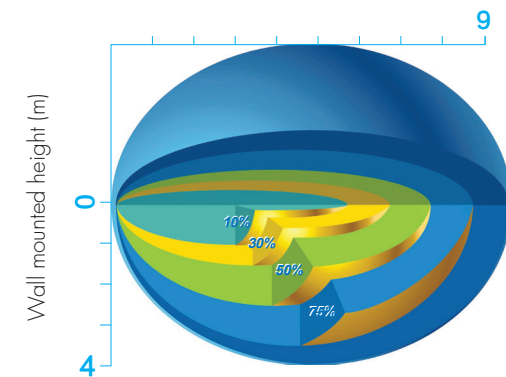

Wall mounted detection pattern (m)

BEAM ANGLE

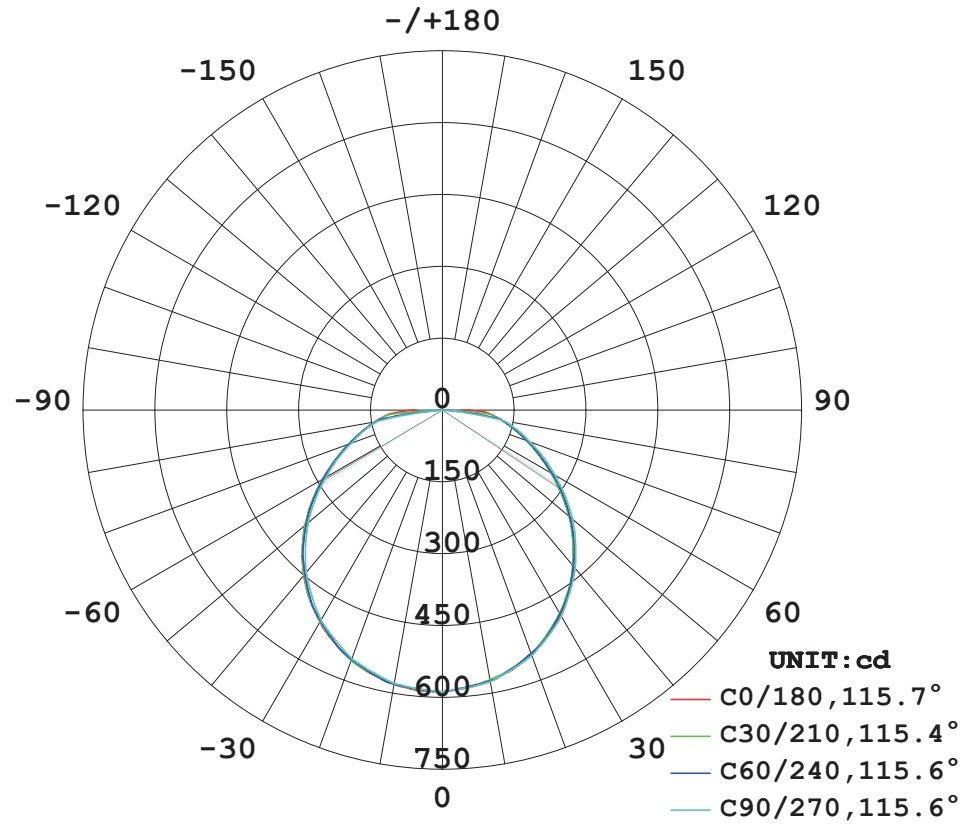

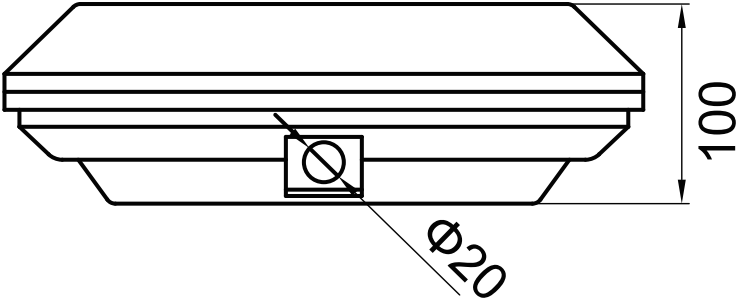
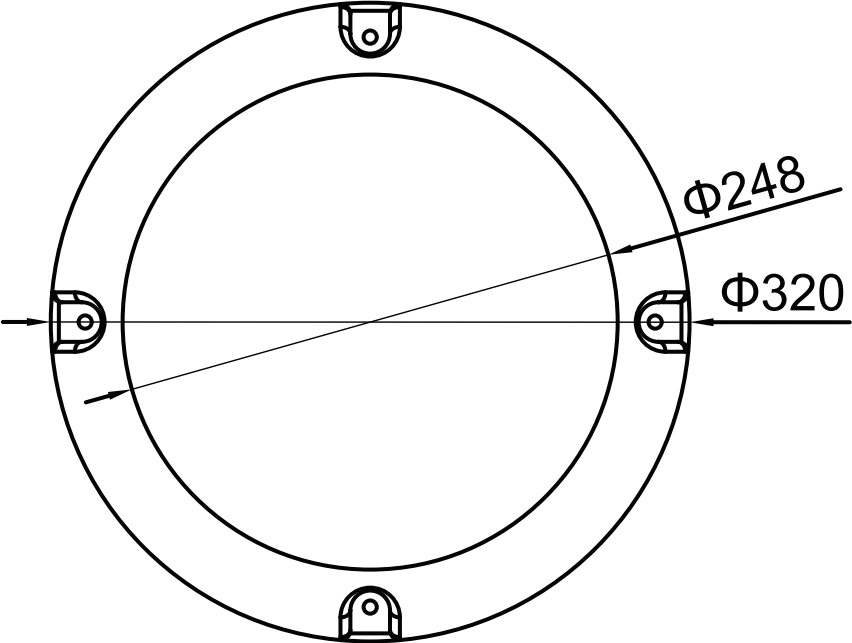

Unit: mm

Fixture Built-in Sensor Photocell Advance Version

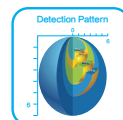
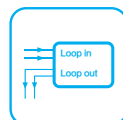
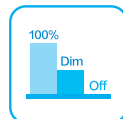
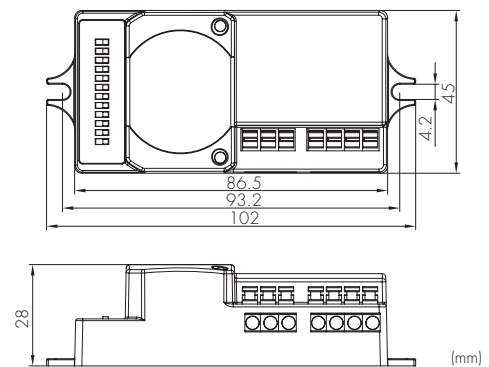
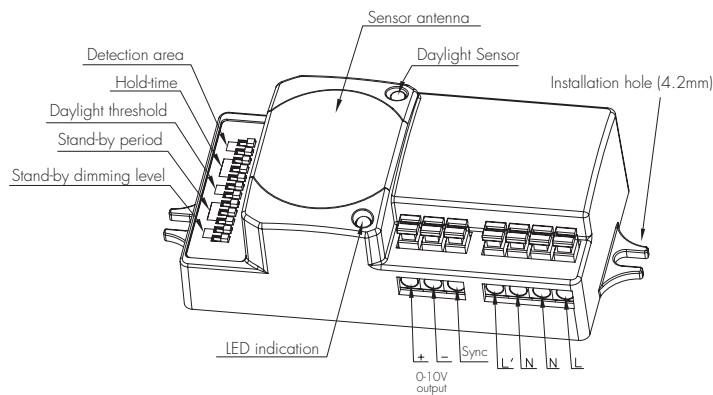

Functions and Features

This sensor allows luminaire design to be simplified as the luminaire body no longer needs to be drilled to accept a photocell for assessing the daylight condition. The light will be turned off completely when the ambient daylight exceeds the pre-set daylight threshold, even there is motion detected during hold-time.

Ideal for applications such as IP rated or sealed luminaires, this product is designed to be enclosed within the luminaire.

1 Tri-level Control (Corridor Function)

Hytronik builds this function inside the motion sensor to achieve tri-level control, for some areas require a light change notice before switch-off. It offers 3 levels of light: 100%->dimmed light ->off; and 2 periods of selectable waiting time: motion hold-time and stand-by period; selectable daylight threshold and freedom of detection area.

2 Photocell Advance (Lux off Function)

The built-in smart daylight sensor can switch off the fixture automatically from behind the fixture cover whenever artificial light is not required. If the stand-by time is pre-set at "+∞", the fixture can automatically turn on at dim level when natural light is insufficient.

Settings on this demonstration:

Hold-time: 10min

Daylight threshold: 50lux

Stand-by dimming level: 10%

Stand-by period: +∞

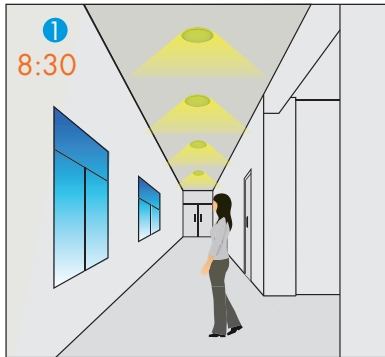

With insufficient natural light, the light switches on at 100% when there is motion detected.

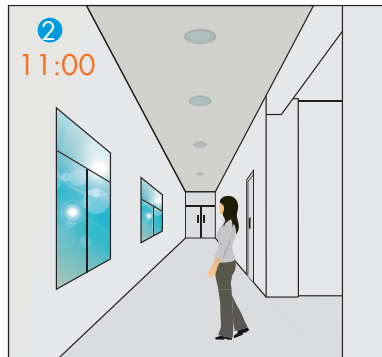

The light turns off completely whenever natural light reaches above pre-set daylight threshold, even with presence.



The light turns on at dim level automatically when natural light lux level drops below pre-set daylight threshold (no motion).

3 Synchronization Control Function

By connecting the "SYNC" terminals in parallel (maximum 10pcs, see wiring diagram overleaf), no matter which sensor detects motion, all HC419V/1 connected will turn on the lights when surrounding natural light is insufficient. The sensor antennas are effectively 'shared' and the detection area is widely enlarged in this way.

Note: To avoid fixtures turning on unnecessarily, daylight sensing takes priority on a point-by-point basis. Occupancy sensing (SYNC) is disabled on those units in which the ambient light exceeds the daylight threshold.

4 Zero-cross relay operation

Designed into the software, the sensor switches on/off the load right at the zero-cross point to ensure the in-rush current is minimized, enabling the maximum lifetime of the relay.

5 Loop-in and loop-out terminal

Double L N terminal makes it easy for wire loop-in and loop-out, and saves the cost of terminal block and assembly time.

6 Wiring diagram

1 sensor controls a group of drivers

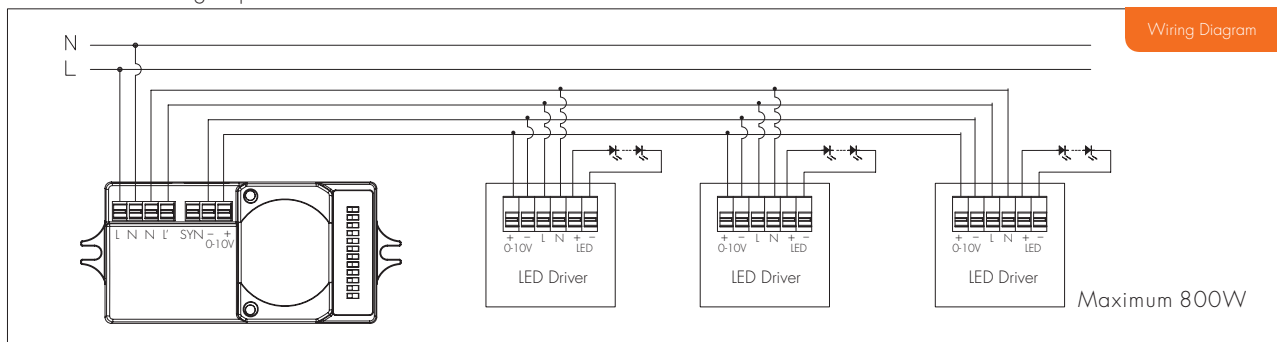

Multiple sensors control the same group of drivers

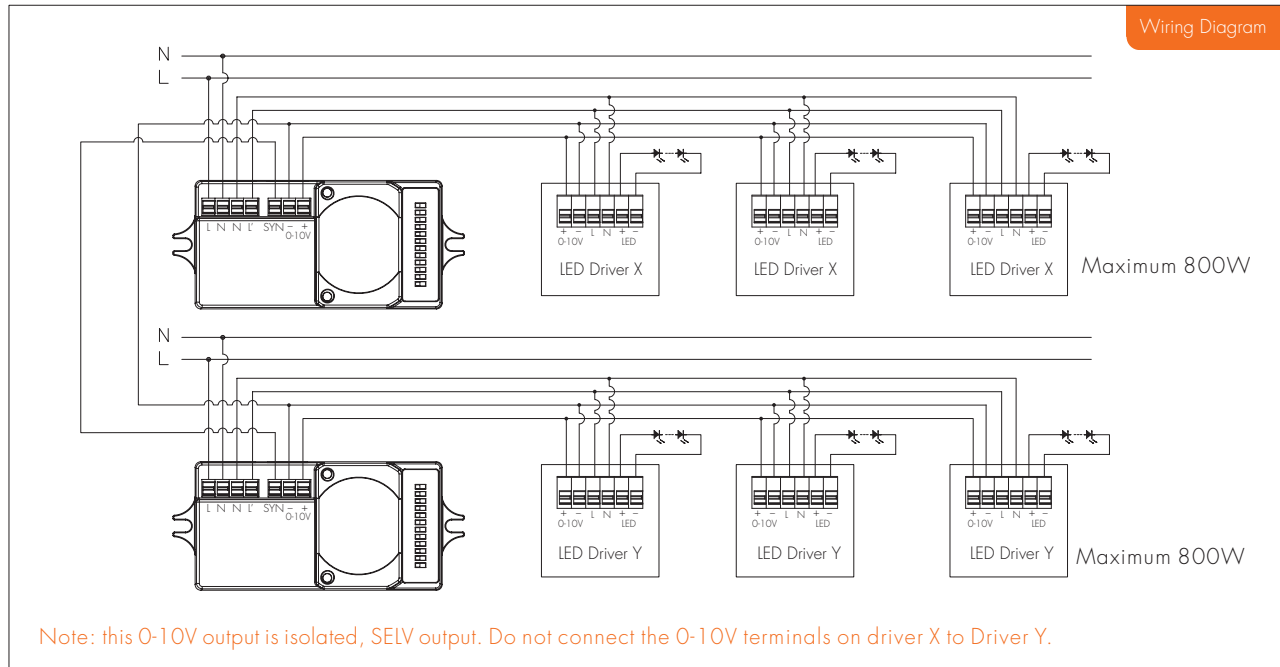

Detection Pattern

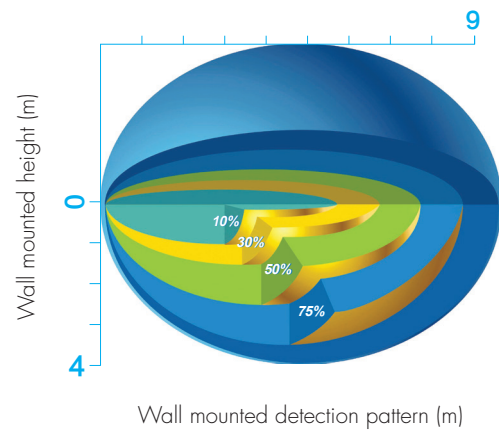
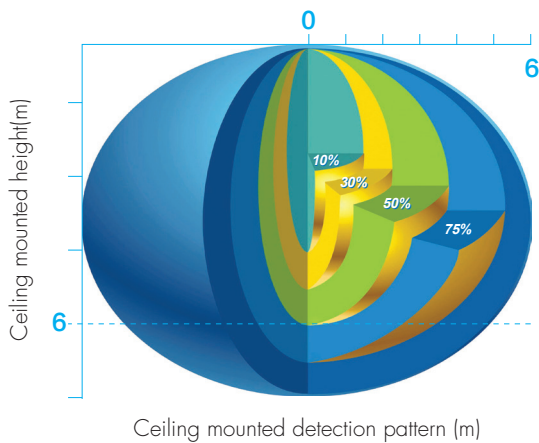

Settings

1 Detection area

Sensor sensitivity can be adjusted by selecting the combination on the DIP switches to fit precisely for each specific application.

	1	2	
I	●	●	100%
II	●	○	75%
III	○	●	50%
IV	○	○	10%



- I – 100%
- II – 75%
- III – 50%
- IV – 10%

2 Hold-time

Select the dip switch configuration for the full brightness on-time after presence detection. This function is disabled when natural light exceeds the daylight threshold setting for more than 5 minutes.

	1	2	3	
I	●	●	●	5s
II	●	●	○	30s
III	●	○	●	1min
IV	●	○	○	5min
V	○	●	●	10min
VI	○	●	○	20min
VII	○	○	○	30min



- I – 5s
- II – 30s
- III – 1min
- IV – 5min
- V – 10min
- VI – 20min
- VII – 30min

3 Daylight sensor

Set the level according to the fixture and environment. This level will determine at which point the fixture turns off and automatically turns back on again. Please note the level refers to internal light reaching the sensor.

	1	2	
I	●	●	Disable
II	●	○	50Lux
III	○	●	10Lux
IV	○	○	2Lux

I – Disable
II – 50Lux
III – 10Lux
IV – 2Lux

4 Stand-by period (corridor function)

This is the time period you would like to keep at the low light output level before it is completely switched off in the long absence of people.

Note: "0s" means on/off control;

"+∞" means the stand-by period is infinite and the light is effectively controlled by the daylight sensor, off when natural light is sufficient and automatically on at dimming level when insufficient.

	1	2	3	
I	●	●	●	0s
II	●	●	○	10s
III	●	○	●	1min
IV	●	○	○	5min
V	○	●	●	10min
VI	○	●	○	30min
VII	○	○	●	1h
VIII	○	○	○	+∞

I – 0s
II – 10s
III – 1min
IV – 5min
V – 10min
VI – 30min
VII – 1h
VIII – +∞

5 Stand-by dimming level

The setting is used to select the desired dimmed light level used in periods of absence for enhanced comfort and safety.

	1	2	
I	●	●	10%
II	●	○	20%
III	○	●	30%
IV	○	○	50%

I – 10%
II – 20%
III – 30%
IV – 50%

Technical Data

Operating voltage	120-277VAC
Switched power (capacitive load)	Max. 400W@120VAC; 1000W@277VAC
Stand-by power	<1W
Warm-up time (Power-on self calibration)	20s
Detection area	10%/50%/75%/100%
Hold-time	5s/30s/1min/5min/10min/20min/30min
Stand-by period	0s/10s/1min/5min/10min/30min/1H/+∞
Stand-by dimming level	10%/20%/30%/50%
Daylight threshold	2~50Lux, disable, can be customized
Sensor principle	Microwave motion detector
Microwave frequency	5.8GHz+/-75MHz
Microwave power	<0.2mW
Detection range	Max. (∅xH): 12m x 6m
Detection angle	30°~150°
Mounting height	Maximum 6m
Operating temperature	-35°C ~ +70°C
Max. case temperature (Tc)	80°C
IP rating	IP20