

CHLOE @ SKY-STAIR 18

SKY-STAIR

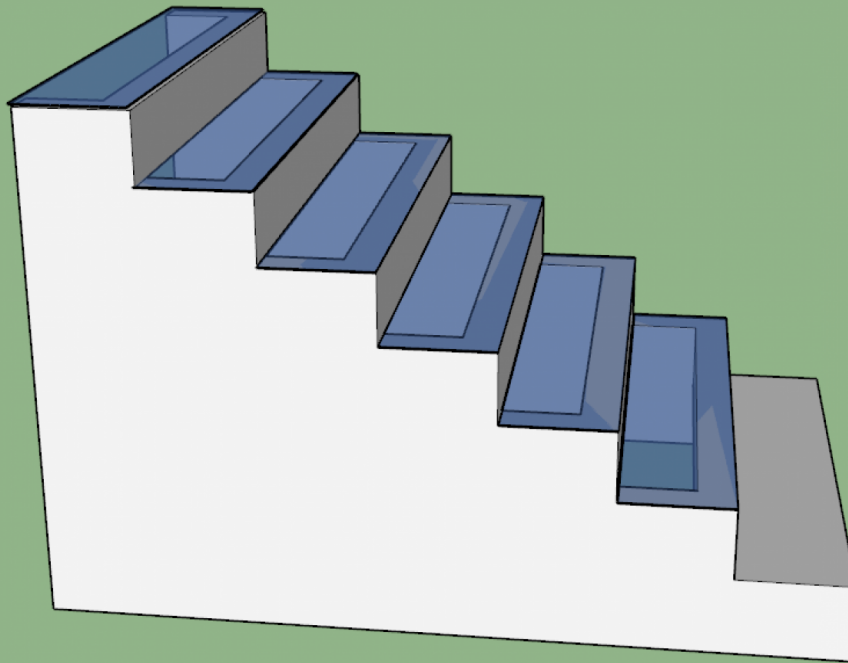

- Building (Construction) Regulations Chapter 123-1990 ;
- Code of Practice on Wind Effects Hong Kong -2004
- Code of Practice for the structural use of Steel -2011
- Code of Practice for the structural use of Concrete-2004 (2nd Edition)
- Code of Practice for the structural use of Aluminium -BS8118: Part 1:1991
- Practice Note for Authorized person, registered structural engineers and registered geotechnical engineers: BD APP-37 (PNAP 106)
- Code of Practice for Dead and Imposed loads-2011

Technical Data

Major Material:

- Stainless Steel Grade S316L with ASTM A511 and Plate with ASTM A240 Proof Stress = 220 MPa
- 8 mm THK Clear Laminated Tempered Glass comply BS 952 Part 1 and BS 6262 , Allowable Stress 50MPa
- Welding comply BS EN 1011-1; BS EN 1011-2; BS EN ISO 15614
- Stainless Steel Fasteners A4-70 comply wiht BS EN ISO 3506-1. Permanent Stain 450Mpa
- Sealants -Dow Corning 795/995/983 or Equivalent Material
- M16.S.S A4-70 Blot & Nut

Tempered Glass color

- Clear
- Dark Grey,
- Euro grey;
- Ocean blue,
- Ford blue,
- Dark blue

Tempered Glass Pattern

Custom-made

Design Basic Wing Pressure

2.04KPa

Color Finishes

Hairline Finish

Certificate



Project	Fixture#	Date
		Firm



Ordering Information

Choose the option that suits your need and write its corresponding code on the appropriate line to form the product code.

Example product code:

CHLOE-AT-SKY-STAIR-18 -

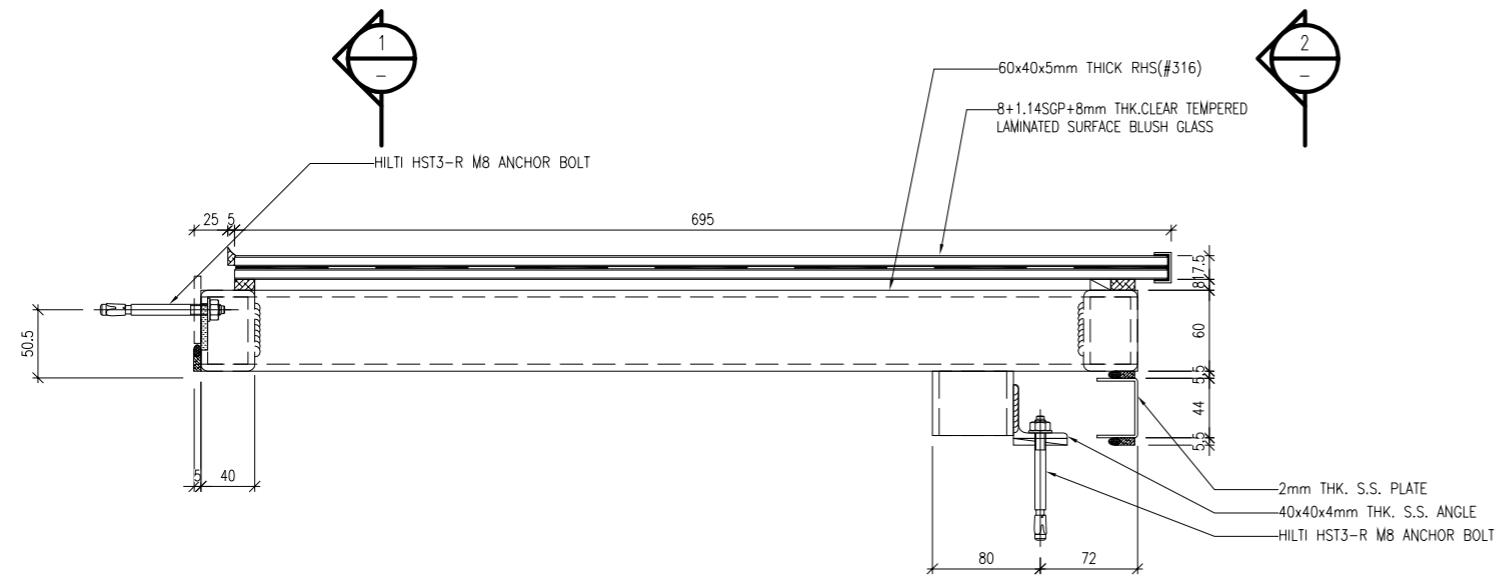

1
-
DETAIL
DE01

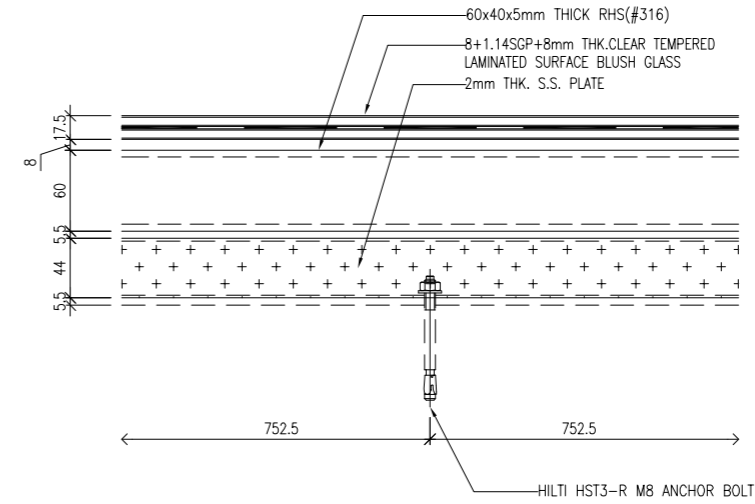

2
-
SECTION

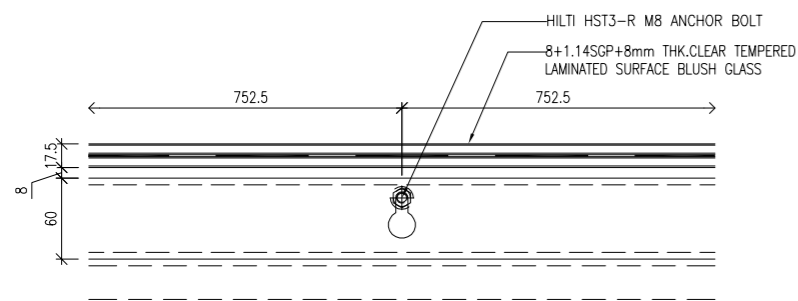

1
-
SECTION

CHLOE@SKY-STAIR18

Drawing Status :

Ref NO.:

Client

Contractor:

Supplier:

DIMON
Technology

DIMON Technology Ltd.
Tel: 00852-3916 5876
Fax: 00852-21203398
Http://www.dimontechnology.com
E-mail:gary@dimontechnology.com

Project:

Job Title:

Drawing Name:

Drawing NO.:

Drawing Scale: AS SHOW

Drawing Date: 2020/06/30

Drawing: KP

Collate: Joyi

Auditing: Gray Hui

Drawing Version: 1

Table of content

Page

1.	Introduction	1
2.	Design Code, Design Data	2 - 3
3.	Design loads	3
4.	Check for laminated tempered glass	4 - 5
5.	Check for steel frame	6 - 10

Appendix

<h1 style="margin: 0;">DIMON</h1> <p style="margin: 0;">TECHNOLOGY</p>		Sheet No.	1
		Prepared by	Y.S.Zhang
Project		Date	16.07.2020
Title	CHLOE @ SKY-STAIR 18	Revision	-

1. Introduction

The skylights are made of 8+8mm thick laminated tempered glass fixed to s.s. RHS by structure sealant
The objective of this calculation is to check the design of skylight to be safe against the dead load, live load and wind load.

Load path

Wind load to skylight → glass panels → steel RHS frame → anchor bolt → r.c. structures

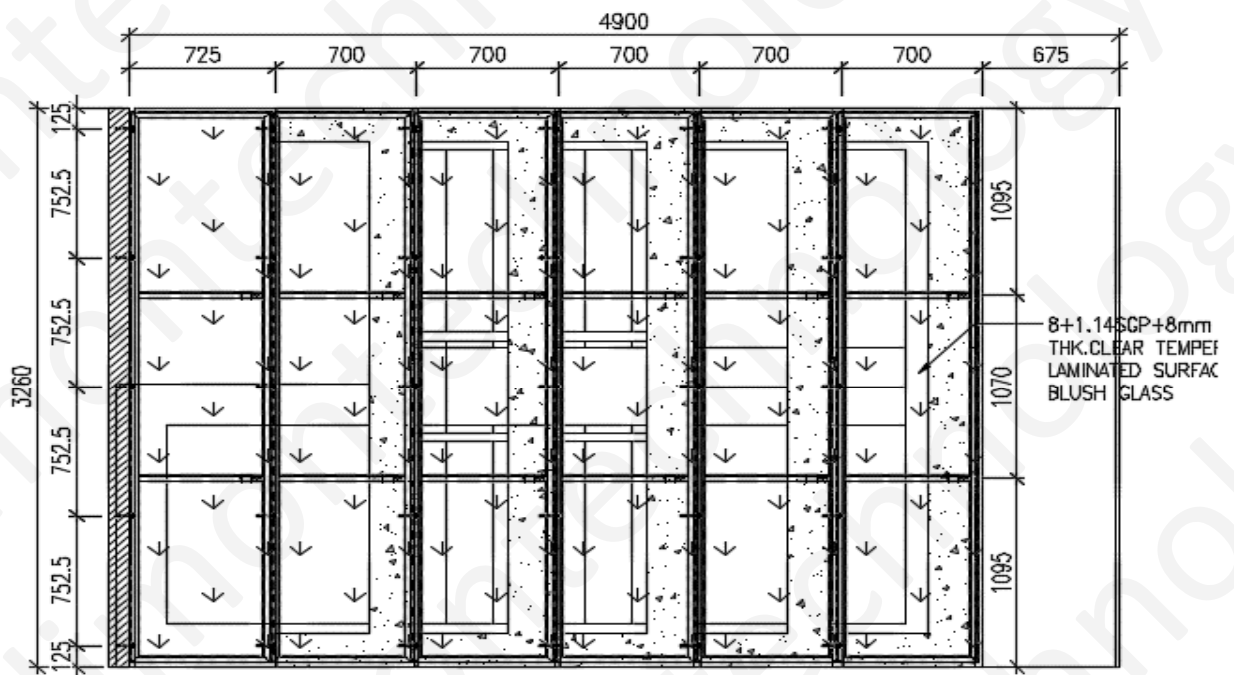

1 TYPE PLAN TO E11
PL01 LOCATION PLAN

		Sheet No.	2
		Prepared by	Y.S.Zhang
Project		Date	16.07.2020
Title	CHLOE @ SKY-STAIR 18	Revision	-

2. Design Code, Design Data

2.1 Design Code

- Hong Kong Building (Construction) Regulation 1990 (Amendment 2011).
- Code of Practice on Wind Effect 2008, Macau.
- Code of Practice for the Structural Use of Steel 2011, Hong Kong
- Code of Practice for the Structural Use of Concrete 2004, Hong Kong
- Code of Practice for Dead and imposed Loads 2011, Hong Kong
- Code of Practice for the Structural Use of Steel GB 50017-2003
- Load Code of the design of buliding structure GB 50009-2012

2.2 Design Data

2.2.1 Stainless steel to be grade X5CrNiMo17-12-2 complied with BS EN 10088

		1.4401 (316 S31)
stainless steel grade		X5CrNiMo17-12-2
0.2% proof stress	(N/mm ²)	220
ultimate tensile strength, min.	(N/mm ²)	510
Modulus of elasticity	(N/mm ²)	200000
Design strength	(N/mm ²)	220
Design stress of fillet weld	(N/mm ²)	220

2.2.2 All welding to be complied with complied to GB50661-2011

steel grade		E50xx
design strength of filled weld	(N/mm ²)	200

2.2.3 All stainless steel bolts or screws to be grade A4 complied to BS EN ISO 3506

class		70
0.2% proof stress	(N/mm ²)	450
ultimate tensile strength	(N/mm ²)	700
design tensile strength	(N/mm ²)	373
design shear strength	(N/mm ²)	280
design bearing strength	(N/mm ²)	805
stainless steel grade		A4 / 316
design bearing strength on connected part	(N/mm ²)	479

DIMON TECHNOLOGY		Sheet No.	3
		Prepared by	Y.S.Zhang
Project		Date	16.07.2020
Title	CHLOE @ SKY-STAIR 18	Revision	-

2.2.4 Concrete

concrete strength,	f_{cu} (N/mm ²)	45	
anchorage bond strength, (= $\beta f_{cu}^{0.5}$)	f_{bu} (N/mm ²)	1.878	$\beta = 0.28$ for cast-in threaded rod
design concrete shear stress,	v_c (N/mm ²)	0.4	
compressive strength, (= $0.6 f_{cu}$)	(N/mm ²)	27	

2.2.5 The data refer to SAP2000 program.

3. Design Load

3.1 Wind load

Wind pressure, $q_z = 1.84$ kPa (height above ground level $\leq 10m$)

Pressure coefficient, = 2 (open frame)

Design wind load
= 2.12×2.0
= 3.68 kPa

3.2 Live load

Live load = 0.75 kN/m²

3.3 Dead Load

Weight of glass	= $(8 + 8) \times 26.5 / 1000$	= 0.424	kPa
Others,	=	= 0.076	kPa
		Total	= 0.5 kPa

<h1 style="text-align: center;">DIMON</h1> <p style="text-align: center;">TECHNOLOGY</p>		Sheet No.	4
		Prepared by	Y.S.Zhang
Project		Date	16.07.2020
Title	CHLOE @ SKY-STAIR 18	Revision	-

4. Check for laminated tempered glass

4.1 Check for 8mm+1.14PVB+8mm clear laminated tempered glass

Glass density,	$\rho = 2650$	kg/m^3		
Nominal thickness of glass pane 1	$= 8$	mm	Min. thickness of glass pane 1,	$t_1 = 7.42$ mm
Nominal thickness of glass pane 2	$= 8$	mm	Min. thickness of glass pane 2,	$t_2 = 7.42$ mm
Glass type for pane 1 & 2	: tempered			
Load duration, self weight	: long term		Reduction factor,	$\gamma_d = 0.66$

Downward load

Basic wind pressure,	$q_z = 1.84$	kN/m^2
Topography factor,	$S_a = 1$	
Pressure coefficient,	$C_p = 2$	
Design wind pressure,	$q_{dn} = q_z S_a C_p = 3.68$	kN/m^2
Live load,	$q_k = 0.75$	kN/m^2
Glass weight $= \rho \Sigma (t / \gamma_d)$,	$g_{k,dn} = 0.6$	kN/m^2

Load combinations (downward)

$1.0 w_{dn} + 1.0 q_k$	$= 4.43$	kN/m^2
$1.3 g_{k,dn} + 0.9 w_{dn} + 1.05 q_k$	$= 4.88$	kN/m^2
$1.2 g_{k,dn} + 1.5 w_{dn} + 1.05 q_k$	$= 7.03$	kN/m^2
$1.2 g_{k,dn} + 0.9 w_{dn} + 1.5 q_k$	$= 5.16$	kN/m^2

Serviceability load,	$w_{dns} = q_{dn} + q_k = 4.43$	kN/m^2
----------------------	---------------------------------	-----------------

Critical combination,	$w_c = 7.03$	kN/m^2
Critical serviceability,	$w_{cs} = 4.43$	kN/m^2

Glass type for pane 1 & 2	: tempered	
Load duration	: short term	
Surface treatment	: clear	

Ultimate resistance strength,	$R_{ult} = p_y \gamma_d \gamma_s / \gamma_m$	
-------------------------------	--	--

Critical load shared equally to each pane,	$w_1 = 7.03 / 2$	
	$= 3.515$	kN/m^2

The glass panel is simply supported on 4 sides.

Longer side of glass pane,	$b = 1095$	mm	$= 1.095$	m
Shorter side of glass pane,	$a = 725$	mm	$= 0.725$	m
Modulus of Elasticity,	$E_g = 70000$	N/mm^2		

Upward load

Basic wind pressure,	$q_z = 1.84$	kN/m^2
Topography factor,	$S_a = 1$	
Pressure coefficient,	$C_p = -2$	
Design wind pressure,	$q_{up} = q_z S_a C_p = -3.68$	kN/m^2
Glass weight $= \rho \Sigma t$,	$g_{k,up} = 0.39$	kN/m^2

Load combinations (upward)

$1.0 w_{up} + 1.0 g_{k,up}$	$= -3.29$	kN/m^2
$1.5 w_{up} + 1.0 g_{k,up}$	$= -5.13$	kN/m^2

Serviceability load,	$w_{ups} = q_{up} + g_s = -3.29$	kN/m^2
----------------------	----------------------------------	-----------------

downward	
downward	(for deflection checking)

Ultimate design strength,	$p_y = 80$	N/mm^2
Reduction factor,	$\gamma_d = 1$	
Reduction factor,	$\gamma_s = 1$	
Material factor,	$\gamma_m = 1$	
	$= 80$	N/mm^2

Critical serviceability load shared equally to each pane	$w_{s1} = 4.43 / 2$	
	$= 2.215$	kN/m^2

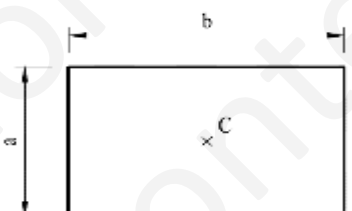

<h1 style="text-align: center;">DIMON</h1> <p style="text-align: center;">TECHNOLOGY</p>		Sheet No.	5
		Prepared by	Y.S.Zhang
Project		Date	16.07.2020
Title	CHLOE @ SKY-STAIR 18	Revision	-

Factored design pressure, $R = 3.515 \text{ kN/m}^2$
Glass type coefficient, $c_1 = 4$
Strength coefficient, $c = c_1 \gamma_d \gamma_s = 4$
Aspect ratio = $b/a = 1.51 < 5$

Min. thickness of glass pane, $= \min [4.87 a^{0.965} b^{0.22} (R/c)^{0.545}, 2.33 (a b)^{0.665} (R/c)^{0.87} - 1.62 (a/b) + 1.2]$
 $= \min (3.28, 1.91) = 1.91 \text{ mm}$
 $\leq 7.42 \text{ mm}$ O.K.

$x = \ln [\ln \{ w_{s1} (ab)^2 / (E_g t^4) \}] = 0.6333$
 $r_0 = 0.553 - 3.83 (b/a) + 1.11 (b/a)^2 - 0.0969 (b/a)^3 = -3.033$
 $r_1 = -2.29 + 5.83 (b/a) - 2.17 (b/a)^2 + 0.2067 (b/a)^3 = 2.2771$
 $r_2 = 1.485 - 1.908 (b/a) + 0.815 (b/a)^2 - 0.0822 (b/a)^3 = 0.1792$

Deflection of glass pane, $\delta_c = t \exp (r_0 + r_1 x + r_2 x^2)$
 $= 1.62 \text{ mm}$
 $\leq 725 / 60 = 12.08 \text{ mm}$ O.K.

Max. bending stress at C, $\sigma_C = 80 \times 1.91^2 / 7.42^2$ (for information only)
 $= 5.3 \text{ N/mm}^2$
 $< 80 \text{ N/mm}^2$ O.K.

Check for structural sealant

Structural sealant bite required $= 3.29 \times 0.725 / 2 / 0.138$
 $= 8.64 \text{ mm}$
 $\leq 20 \text{ mm}$ O.K.

<h1 style="text-align: center;">DIMON</h1> <p style="text-align: center;">TECHNOLOGY</p>		Sheet No.	6
		Prepared by	Y.S.Zhang
Project		Date	16.07.2020
Title	CHLOE @ SKY-STAIR 18	Revision	-

5. Check for steel frame

5.1 Check for 600x40x5mm s.s. RHS

Vertical load = 7.03 kN/m²

UDL = 7.03 x 0.725 / 2 = 2.55 kN/m²

Distance of support = 1095 mm

Reaction at support R1 = 2.55 x 1.095 / 2 = 1.396 kN

Max bending moment = 2.55 x 1.095² / 8 = 0.38 kNm

Shear stress = 1.396 x 1000 / (2 x 5 x 60) = 2.33 N/mm²
 < 0.6 x 127 = 76.2 N/mm² (low shear)

Moment capacity = min(1.2 p_y Z_y, p_y S_y) = (1.2 x 220 x 13/1000, 220 x 16.4 / 1000) = 3.432 kNm (factored)
 > 0.38 kNm O.K.

Max deflection = 5/348 x 4.43 x 0.725 / 2 x 1095⁴ / (200000 x 3810000) = 0.435 mm (unfactored)
 < 1095 / 250 = 4.38 mm O.K.

Check for lateral torsional buckling

Design strength, p_y = 220 N/mm² Parameter, ε = (275 / p_y)^{0.5} = 1.118

Modulus of Elasticity, E = 200000 N/mm²

Overall width, B = 40 mm Overall depth, D = 60 mm

Wall thickness, t = 5 mm Area, A = 8.73 cm²

Moment of inertia, I_x = 38.1 cm⁴ Moment of inertia, I_y = 19.5 cm⁴

Section modulus, Z_x = 12.7 cm³ Section modulus, Z_y = 9.77 cm³

Plastic modulus, S_x = 16.4 cm³ Plastic modulus, S_y = 12.2 cm³

Torsional constant, J = 43 cm⁴ Radius of gyration, r_y = 1.5 cm

Effective length, L_E = 1095 mm

Slenderness ratio, λ = L_E / r_y = 73

γ_b = (1 - I_y / I_x) [1 - J / (2.6 I_x)] = 0.2763

Sheet No.	7
Prepared by	Y.S.Zhang
Date	16.07.2020
Revision	-

Project	
Title	CHLOE @ SKY-STAIR 18

Buckling index, Ratio, $\alpha_b = [S_x^2 \gamma_b / (A J)]^{0.5} = 0.4449$
 $\beta_w = 1$ for plastic section

Equivalent slenderness, $\lambda_{LT} = 2.25 (\alpha_b \lambda \beta_w)^{0.5} = 12.82$
 $P_E = \pi^2 E / \lambda_{LT}^2 = 12010.3$
 $\alpha_{LT} = 7$
 $\lambda_{L0} = 0.4 (\pi^2 E / p_y)^{0.5} = 37.89$

Perry factor, $\eta_{LT} = \alpha_{LT} (\lambda_{LT} - \lambda_{L0}) / 1000 = -0.1755 < 0$
 $\phi_{LT} = [p_y + (\eta_{LT} + 1) P_E] / 2 = 5061.25$

Bending buckling strength, $p_b = P_E p_y / (\phi_{LT}^2 + (\phi_{LT}^2 - P_E p_y)^{0.5})$
 $= 268.13 \text{ N/mm}^2$
 $> 220 \text{ N/mm}^2$

Check for 4mm fillet weld connector channel to steel frame

Horizontal load, $= 2 \times 1.396 = 2.792 \text{ kN}$

Effective length of fillet weld, $= 2 \times (60 + 40) = 200 \text{ mm}$

Capacity of fillet weld $= 200 \times 200 \times 4 \times 0.7 / 1000 = 112 \text{ kN}$
 $> 2.792 \text{ kN}$ O.K.

5.2 Check for 4mm fillet weld 2 sides connection to angle

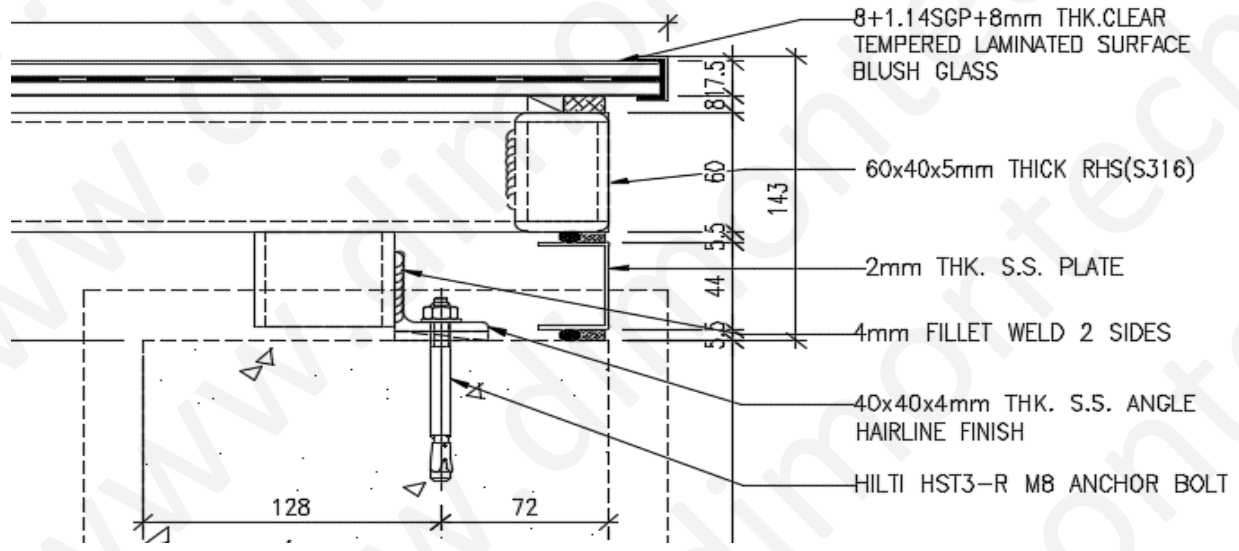

Sheet No.	8
Prepared by	Y.S.Zhang
Date	16.07.2020
Revision	-

Project		Date	16.07.2020
Title	CHLOE @ SKY-STAIR 18	Revision	-

Design wind pressure = 3.68 kN/m²

Vertical load = 2.792 kN (refer to item 5.1)

Hori. Wind load = 1.5 x 3.68 x 0.143 x 1.095 (factored)
= 0.86 kN

Combined loads = $(2.792^2 + 0.86^2)^{0.5}$
= 2.92 kN

Effective length of fillet weld, = 2 x (30 - 2 x 4)
= 44 mm

Capacity of fillet weld = 200 x 44 x 4 x 0.7 / 1000
= 24.64 kN
> 2.92 kN O.K.

5.3 Check for 40x40x4mm s.s. angle

Vertical load = 2.792 kN (refer to item 5.1)

Hori. Wind load = 0.86 kN (refer to item 5.2)

Eccentricity $e_x = 20$ mm
 $e_y = 20$ mm

Bending moment due to eccentricity = 2.792 x 20 + 1 x 20
= 73.04 kNmm

Moment capacity = 220 x 120 x 4² / 4 / 1000
= 105.6 kNmm
> 73.04 kNmm O.K.

Sheet No.	9
Prepared by	Y.S.Zhang
Date	16.07.2020
Revision	-

Project	
Title	CHLOE @ SKY-STAIR 18

5.3 Check for HST3-R anchor bolt

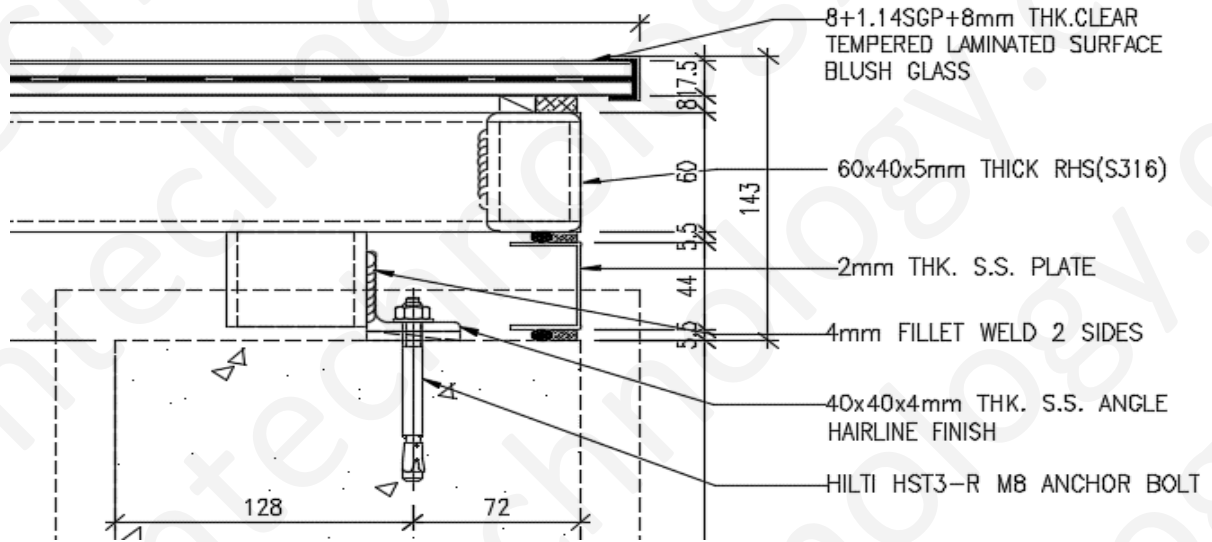

Vertical load = $3.68 / 7.03 \times 2.792$ (upward load)
 = 1.462 kN (refer to item 5.1)

Hori. Wind load = $3.68 \times 0.143 \times 1.095$ (unfactored)
 = 0.58 kN

Tensiel load on per anchor bolt = $(1.462 \times 20 + 0.58 \times 20) / (20 \times 5 / 6)$
 = 2.45 kN

Shearl load on per anchor bolt = 0.58 kN

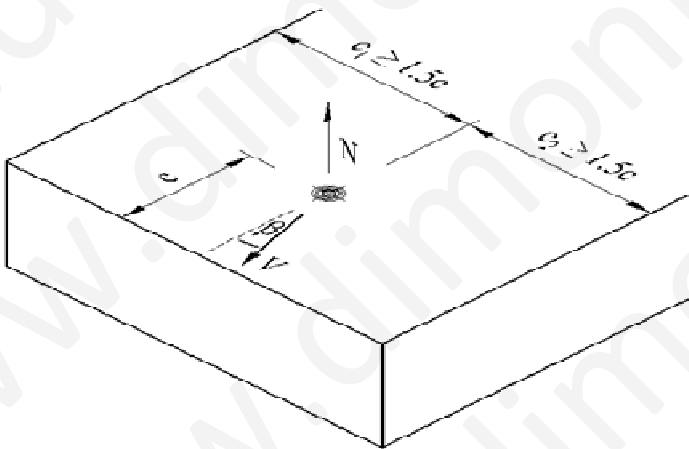

Factor of safety, $\gamma = 3$ (cracked concrete)

Design concrete strength, $f_{ck,cube} = 45$ N/mm²

Influence on concrete strength, $f_B = (f_{ck,cube} / 25)^{0.5} = 1.342$

<h1 style="text-align: center;">DIMON</h1> <p style="text-align: center;">TECHNOLOGY</p>		Sheet No.	10
		Prepared by	Y.S.Zhang
Project		Date	16.07.2020
Title	CHLOE @ SKY-STAIR 18	Revision	-

Thickness of concrete,	$h = 200$	mm	Min. concrete thickness,	$h_{min} = 100$	mm
			Effective anchorage depth,	$h_{ef} = 47$	mm
Min. edge distance,	$c_{min} = 40$	mm	Critical edge distance,	$c_{cr,N} = 71$	mm
Min. spacing,	$s_{min} = 35$	mm	Critical spacing,	$s_{cr,N} = 141$	mm
Edge distance,	$c = 72$	mm			
Basic pull-out resistance,	$N_{Rd,p}^0 = 5$	kN	with safety factor,	$\gamma_{Mp} = 1.5$	
Design pull-out resistance,	$N_{Rd,p} = \gamma_{Mp} N_{Rd,p}^0 f_B / \gamma$			$= 3.36$	kN
Basic concrete cone resistance,	$N_{Rd,c}^0 = 7.7$	kN	with safety factor,	$\gamma_{Mc} = 1.5$	
Influence on edge distance,	$f_{1N} = \min [0.7 + 0.3 c / c_{cr,N}, 1]$			$= 1$	
	$f_{2N} = \min [0.5 (1 + c / c_{cr,N}), 1]$			$= 1$	
Influence on reinforcement,	$f_{re,N} = \min [0.5 + h_{ef} / 200, 1]$			$= 0.735$	
Design concrete cone resistance,	$N_{Rd,c} = \gamma_{Mc} N_{Rd,c}^0 f_B f_{1N} f_{2N} f_{re,N} / \gamma$			$= 3.8$	kN
Recommended tensile load,	$N_{Rec} = \min (N_{Rd,p}, N_{Rd,c})$				
	$= 3.36$	kN			
	≥ 2.45	kN			O.K.
Basic steel resistance,	$V_{Rd,s}^0 = 12.6$	kN	with safety factor,	$\gamma_{Ms} = 1.25$	
Design steel resistance,	$V_{Rd,s} = \gamma_{Ms} V_{Rd,s}^0 / \gamma$			$= 5.25$	kN
Basic conc. prying resistance,	$V_{Rd,cp}^0 = 20.02$	kN	with safety factor,	$\gamma_{Mc} = 1.5$	
Design conc. prying resistance,	$V_{Rd,cp} = \gamma_{Mc} V_{Rd,cp}^0 f_B f_{1N} f_{2N} f_{re,N} / \gamma$			$= 9.87$	kN
Basic conc. edge resistance,	$V_{Rd,c}^0 = 4.2$	kN	with safety factor,	$\gamma_{Mc} = 1.5$	
Influence on shear load direction,	$f_{\beta} = 1$		for shear load direction,	$\beta = 0^\circ$	
Influence on concrete thickness,	$f_h = \min \{ [h / (1.5 c)]^{2/3}, 1 \}$			$= 1$	
Influence on edge distance,	$f_4 = (c / h_{ef})^{1.5}$			$= 1.896$	
Design concrete edge resistance,	$V_{Rd,c} = \gamma_{Mc} V_{Rd,c}^0 f_B f_{\beta} f_h f_4 / \gamma$			$= 5.34$	kN
Recommended shear load,	$V_{Rec} = \min (V_{Rd,s}, V_{Rd,cp}, V_{Rd,c})$				
	$= 5.25$	kN			
	≥ 0.58	kN			O.K.
Combined tensile & shear loads	$= (N / V_{Rec})^{1.5} + (V / V_{Rec})^{1.5}$				
	$= 0.659$				
	≤ 1				O.K.